

**LEKI**

**LEKI CROSS  
TRAIL**



# CROSS TRAIL

22

- POLES**
- 2 MCT 12 VARIO CARBON
  - 4 FOLDING POLES VARIO
  - 5 FOLDING | FIXED LENGTH
  - 68 POLE OVERVIEW

# TREKKING

68

- POLES**
- 6 MICRO VARIO CARBON
  - 8 FOLDING POLES
  - 12 SUPERSTRONG
  - 13 ULTRALITE
  - 15 KIDS
  - 16 LADIES
  - 18 SLS VINTAGE LINE
  - 20 LEGEND SERIES
  - 68 POLE OVERVIEW

# TRAIL RUNNING

22

- POLES**
- 22 MICRO TRAIL RACE
  - 24 FOLDING | FIXED LENGTH
  - 26 FOLDING POLES VARIO
  - 27 FIXED LENGTH
  - 70 POLE OVERVIEW

# NORDIC WALKING

28

- POLES**
- 28 PACEMAKER LITE
  - 30 SPEED TIP
  - 30 FLEX TIP
  - 32 FOLDING | FIXED LENGTH
  - 33 SMART TIP 2.0
  - 34 VARIO
  - 35 KIDS
  - 70 POLE OVERVIEW

# SKI ROLLER

36

- POLES**
- 37 FIN VARIO
  - 37 VARIO
  - 71 POLE OVERVIEW

# GLOVES

40

- GLOVES**
- 40 TRIGGER SHARK BOA®
  - 41 TRIGGER SHARK
  - 43 ALLROUND

# ACCESSORIES

44

- 44 APPAREL HEADWEAR
- 46 BAGS
- 48 SPAREPARTS

# TECHNOLOGY

52

- 52 MATERIAL INDEX SHAFTS
- 53 CROSS SHARK GRIP
- 54 AERCON GRIP
- 55 EVOCON GRIP
- 56 FOLDING POLES
- 58 TRIGGER SHARK 2.0
- 60 LOCKING SYSTEM
- 62 DSS
- 62 SMART TIP 2.0
- 63 TREKKING BASKET 2.0
- 63 FIN VARIO
- 64 TIPS & PADS
- 65 GLOVE TECHNOLOGY
- 72 IMPRESSUM



**FAST • LIGHT • VERSATILE**  
MCT 12 VARIO CARBON



weight: 200 g  
pack size: 42 cm  
length: 110 - 130 cm adjustable

**MCT 12 VARIO CARBON** 650 26801 Reorder Model 2021



Längen Length 110-130 cm  
 Packmaß Pack size 42 cm  
 Gewicht Weight 200 g  
 Material Material Carbon (HRC) Ø 14 / 12 mm

**OutDoor**  
by ISPO  
Outstanding Outdoor  
Winner 2019



**CROSS SHARK**

**MCT SUPERLITE CARBON** 651 25561

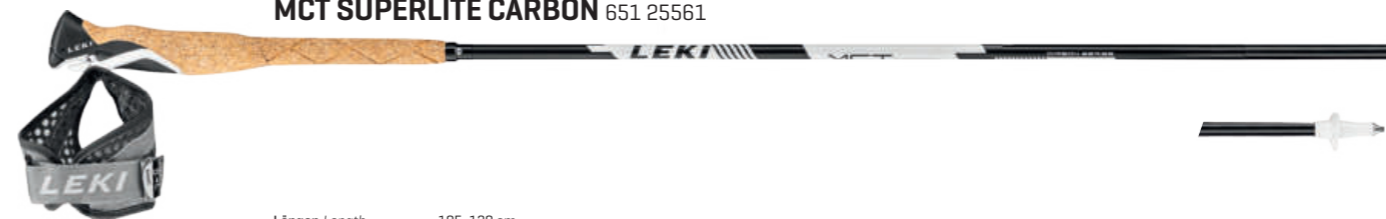

Längen Length 105-130 cm  
 Packmaß Pack size 37 cm (120 cm)  
 Gewicht Weight 158 g (120 cm)  
 Material Material Carbon (HRC) Ø 14 / 12 mm



**CROSS SHARK**

**MCT 12 VARIO CARBON WOMEN** 650 26851 Reorder Model 2021



Längen Length 100-120 cm  
 Packmaß Pack size 42 cm  
 Gewicht Weight 190 g  
 Material Material Carbon (HRC) Ø 14 / 12 mm



**CROSS SHARK**

**MCT VARIO TA** 650 26601 Reorder Model 2021



Längen Length 110-130 cm  
 Packmaß Pack size 43 cm  
 Gewicht Weight 258 g  
 Material Material Aluminium (HTS 6.5) Ø 16 / 14 mm



**CROSS SHARK**

**MCT VARIO TA WOMEN** 650 26651 Reorder Model 2021



Längen Length 100-120 cm  
 Packmaß Pack size 43 cm  
 Gewicht Weight 249 g  
 Material Material Aluminium (HTS 6.5) Ø 16 / 14 mm



**CROSS SHARK**





STEFAN GLOWACZ (GER)

**LIGHT • VERSATILE • RELIABLE**  
MICRO VARIO CARBON



weight: 240 g  
pack size: 40 cm  
length: 110 - 130 cm adjustable

## TREKKING FOLDING POLES

Kleinstes Packmaß – Geringes Gewicht – Schnelle, einfache Handhabung.  
Vielfältiger Einsatz. Speziell zum Trekking, Klettersteig-Zustieg und auf Reisen.  
Trittsicherheit erforderlich.

*Minimum pack size – minimum weight – fast and easy handling.  
Multi functional. Perfect for trekking, reaching a Via Ferrata and travel.  
Surefootedness required.*

*Encombrement minimal – poids minimal – Maniement facile et rapide.  
Multi-fonctionnel. Parfait pour le trekking, atteindre une Via Ferrata et les voyages.  
Agilité requise.*

*Minimo ingombro – peso ridotto – veloce e semplice maneggevolezza.  
Usa versatile. Ideale soprattutto per trekking, avvicinamento, via ferrate e viaggi.  
È necessario un passo sicuro.*



**MICRO VARIO CARBON ANTISHOCK 649 2063**



Längen Length	110-130 cm
Packmaß Pack size	40 cm
Gewicht Weight	252 g
Material Material	Carbon (PRC 1000)   Aluminium (HTS 6.5)









**MICRO VARIO CARBON LADY ANTISHOCK 649 2059**



Längen Length	100-120 cm
Packmaß Pack size	40 cm
Gewicht Weight	240 g
Material Material	Carbon (PRC 1000)   Aluminium (HTS 6.5)









**BLACK SERIES 649 2900**



Längen Length	110-130 cm
Packmaß Pack size	40 cm
Gewicht Weight	207 g
Material Material	Carbon (PRC 1000)











**MICRO VARIO CARBON 651 20621 / 649 2062 Reorder Model 2021**





Längen Length	110-130 cm
Packmaß Pack size	40 cm
Gewicht Weight	240 g
Material Material	Carbon (PRC 1000)















**MICRO VARIO CARBON LADY 649 2067 Reorder Model 2021**



Längen Length	100-120 cm
Packmaß Pack size	40 cm
Gewicht Weight	230 g
Material Material	Carbon (PRC 1000)

**MICRO VARIO CARBON STRONG** 649 2980



Längen Length 120-140 cm  
 Packmaß Pack size 37 cm  
 Gewicht Weight 290 g  
 Material Material Carbon 100 % / Aluminium HTS 6.5  
 Ø 20 / 18 / 16 mm



**MICRO VARIO TA** 649 2075 Reorder Model 2021



Längen Length 110-130 cm  
 Packmaß Pack size 38 cm  
 Gewicht Weight 267 g  
 Material Material Aluminium (HTS 6.5)  
 Ø 18 / 16 / 14 mm



**MICRO VARIO TA EVO** 651 22451



Längen Length 110-130 cm  
 Packmaß Pack size 40 cm  
 Gewicht Weight 288 g  
 Material Material Aluminium (HTS 6.0)  
 Ø 18 / 16 / 14 mm



TREKKING  
 FOLDING POLES | VARIO

TREKKING  
 FOLDING | FIXED LENGTH





## TREKKING SUPERSTRONG

Robuste Kategorie mit hoher, funktioneller Stabilitäts- und Sicherheitsreserve.  
Zielgruppe: Ab 180 cm Körpergröße und / oder ab 75 kg Gewicht.

*Sturdy poles with highly functional stability and safety reserves.  
Target group: People of a height of 180 cm or more and / or a weight of 75 kg or more.*

Des bâtons costauds et très fonctionnels, qui offrent une réserve de stabilité et de sécurité à leur utilisateur.  
Groupe cible: les randonneurs de plus de 180 cm et / ou de plus de 75 kg.

*Bastoni robusti con elevate riserve di stabilità funzionale e di sicurezza.  
Gruppo di utilizzo: per stature di 180 cm di altezza e oltre e / o un peso corporeo di 75 kg e oltre.*



**SHERPA XTG ANTISHOCK** 649 2029

Längen Length (71) 110-145 cm  
Gewicht Weight 270 g  
Material Material Aluminium (HTS 6.5)  
Ø 18 / 16 / 14 mm



**SHERPA XTG** 649 2028

Längen Length (70) 110-145 cm  
Gewicht Weight 263 g  
Material Material Aluminium (HTS 6.5)  
Ø 18 / 16 / 14 mm



**MAKALU** 649 2849 Reorder Model 2021

Längen Length (71) 110-145 cm  
Gewicht Weight 255 g  
Material Material Aluminium (HTS 6.5)  
Ø 18 / 16 / 14 mm



## TREKKING ULTRALITE

Weniger Gewicht – kürzeres Packmaß – perfekter Komfort.  
Zielgruppe: Bis 180 cm Körpergröße und / oder 75 kg Gewicht.

*Less weight – reduced packaging size – perfect comfort.  
Target group: People of a height of 180 cm or less and / or a weight of 75 kg or less.*

Un poids moindre, une compacité accrue, pour un confort parfait.  
Groupe Cible: les randonneurs jusqu'à 180 cm et / ou 75 kg.

*Meno peso – misura di ingombro ridotta – comfort perfetto.  
Gruppo di utilizzo: per stature fino a 180 cm e / o 75 kg di peso corporeo.*



**CARBON TA XTG** 649 2160

Längen Length (68) 100-135 cm  
Gewicht Weight 215 g  
Material Material Aluminium (HTS 6.5) | Carbon (PRC 1000)  
Ø 16 / 14 / 12 mm



**SHERPA LITE XTG** 649 2135

Längen Length (68) 100-135 cm  
Gewicht Weight 240 g  
Material Material Aluminium (HTS 6.5)  
Ø 16 / 14 / 12 mm



**MAKALU LITE** 649 2108 Reorder Model 2021

Längen Length (67) 100-135 cm  
Gewicht Weight 235 g  
Material Material Aluminium (HTS 6.5)  
Ø 16 / 14 / 12 mm





**KHUMBU ANTISHOCK** 649 2026 Reorder Model 2021



Längen Length [71] 110-145 cm  
 Gewicht Weight 278 g  
 Material Material Aluminium (HTS 6.5)  
 Ø 18 / 16 / 14 mm







**KHUMBU** 649 2043 Reorder Model 2021



Längen Length [71] 110-145 cm  
 Gewicht Weight 270 g  
 Material Material Aluminium (HTS 6.5)  
 Ø 18 / 16 / 14 mm







**LEGACY** 651 20191 Reorder Model 2021



Längen Length [70] 110-145 cm  
 Gewicht Weight 275 g  
 Material Material Aluminium (HTS 6.0)  
 Ø 18 / 16 / 14 mm









**KHUMBU LITE ANTISHOCK** 649 2156



Längen Length [68] 100-135 cm  
 Gewicht Weight 253 g  
 Material Material Aluminium (HTS 6.5)  
 Ø 16 / 14 / 12 mm









**KHUMBU LITE** 649 2153 Reorder Model 2021



Längen Length [67] 100-135 cm  
 Gewicht Weight 245 g  
 Material Material Aluminium (HTS 6.5)  
 Ø 16 / 14 / 12 mm









**LEGACY LITE ANTISHOCK** 651 21831



Längen Length [68] 100-135 cm  
 Gewicht Weight 260 g  
 Material Material Aluminium (HTS 6.0)  
 Ø 16 / 14 / 12 mm









**LEGACY LITE** 651 21841 Reorder Model 2021



Längen Length [66] 100-135 cm  
 Gewicht Weight 250 g  
 Material Material Aluminium (HTS 6.0)  
 Ø 16 / 14 / 12 mm







**VARIO XS** 649 20521



Längen Length [67] 80-110 cm  
 Gewicht Weight 212 g  
 Material Material Aluminium (HTS 5.5)  
 Ø 14 / 12 mm









  
 kids



**MICRO VARIO CARBON LADY ANTISHOCK** 649 2059

Längen Length 100-120 cm  
 Packmaß Pack size 40 cm  
 Gewicht Weight 240 g  
 Material Material Carbon (PRC 1000) | Aluminium (HTS 6.5)  
 Ø 18 / 16 / 14 mm

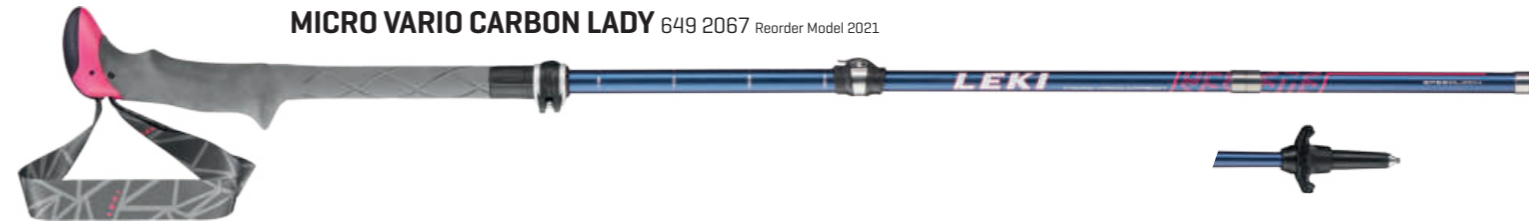

**MICRO VARIO CARBON LADY** 649 2067 Reorder Model 2021

Längen Length 100-120 cm  
 Packmaß Pack size 40 cm  
 Gewicht Weight 230 g  
 Material Material Carbon (PRC 1000)  
 Ø 18 / 16 / 14 mm

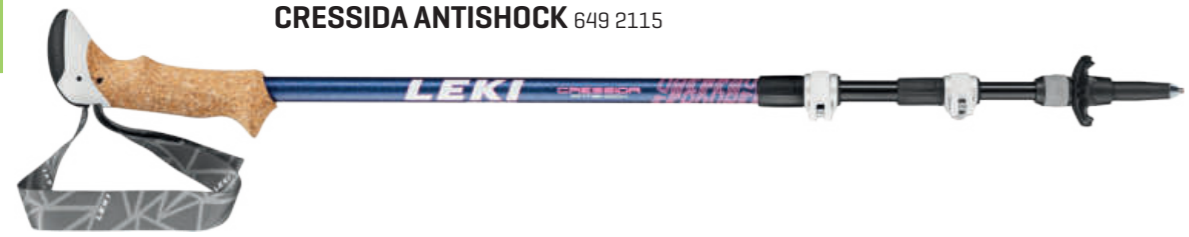

**CRESSIDA ANTISHOCK** 649 2115

Längen Length [64] 90-125 cm  
 Gewicht Weight 235 g  
 Material Material Aluminium (HTS 6.0)  
 Ø 16 / 14 / 12 mm



**CRESSIDA** 649 2119 Reorder Model 2021

Längen Length [64] 90-125 cm  
 Gewicht Weight 220 g  
 Material Material Aluminium (HTS 6.0)  
 Ø 16 / 14 / 12 mm





**TRAIL ANTISHOCK** 650 20351

Längen Length [69] 110-145 cm  
Gewicht Weight 282 g  
Material Material Aluminium (HTS 6.0)  
Ø 18 / 16 / 14 mm

Round Top Comfort



**TRAIL** 650 20211 Reorder Model 2021

Längen Length [65] 110-145 cm  
Gewicht Weight 274 g  
Material Material Aluminium (HTS 6.0)  
Ø 18 / 16 / 14 mm

Round Top Comfort



**VOYAGER** 650 20171 Reorder Model 2021

Längen Length [65] 110-145 cm  
Gewicht Weight 276 g  
Material Material Aluminium (HTS 6.0)  
Ø 18 / 16 / 14 mm



**EAGLE** 650 20111

Längen Length [65] 110-145 cm  
Gewicht Weight 276 g  
Material Material Aluminium (HTS 6.0)  
Ø 18 / 16 / 14 mm



**BLACK SERIES SLS XTG** 651 21291

Längen Length [68] 100-135 cm  
Gewicht Weight 185 g  
Material Material Carbon (PRC 1000)  
Ø 16 / 14 / 12 mm



**TRAIL LITE** 650 21261

Längen Length [61] 100-135 cm  
Gewicht Weight 220 g  
Material Material Aluminium (HTS 6.0)  
Ø 16 / 14 / 12 mm



**DOLOMIT LITE** 650 28341

Längen Length [61] 100-135 cm  
Gewicht Weight 248 g  
Material Material Aluminium (HTS 6.0)  
Ø 16 / 14 / 12 mm



**LEGEND SERIES MICRO** 650 20871



Längen Length 85-100 cm  
 Packmaß Pack size 38 cm  
 Gewicht Weight 227 g  
 Material Material Carbon [PRC 1000]  
 Ø 18 / 16 / 14 mm



**LEGEND SERIES** 650 20861



Längen Length 63-120 cm  
 Gewicht Weight 240 g  
 Material Material Carbon [PRC 1000]  
 Ø 18 / 16 / 14 mm



**WANDERFREUND MAKALU** 650 20811 Reorder Model 2021



Längen Length 63-120 cm  
 Gewicht Weight 277 g  
 Material Material Aluminium [HTS 6.5]  
 Ø 18 / 16 / 14 mm



**SUPER MICRO** 650 20801



Längen Length 46-90 cm  
 Gewicht Weight 228 g  
 Material Material Aluminium [HTS 6.5]  
 Ø 18 / 16 / 14 mm

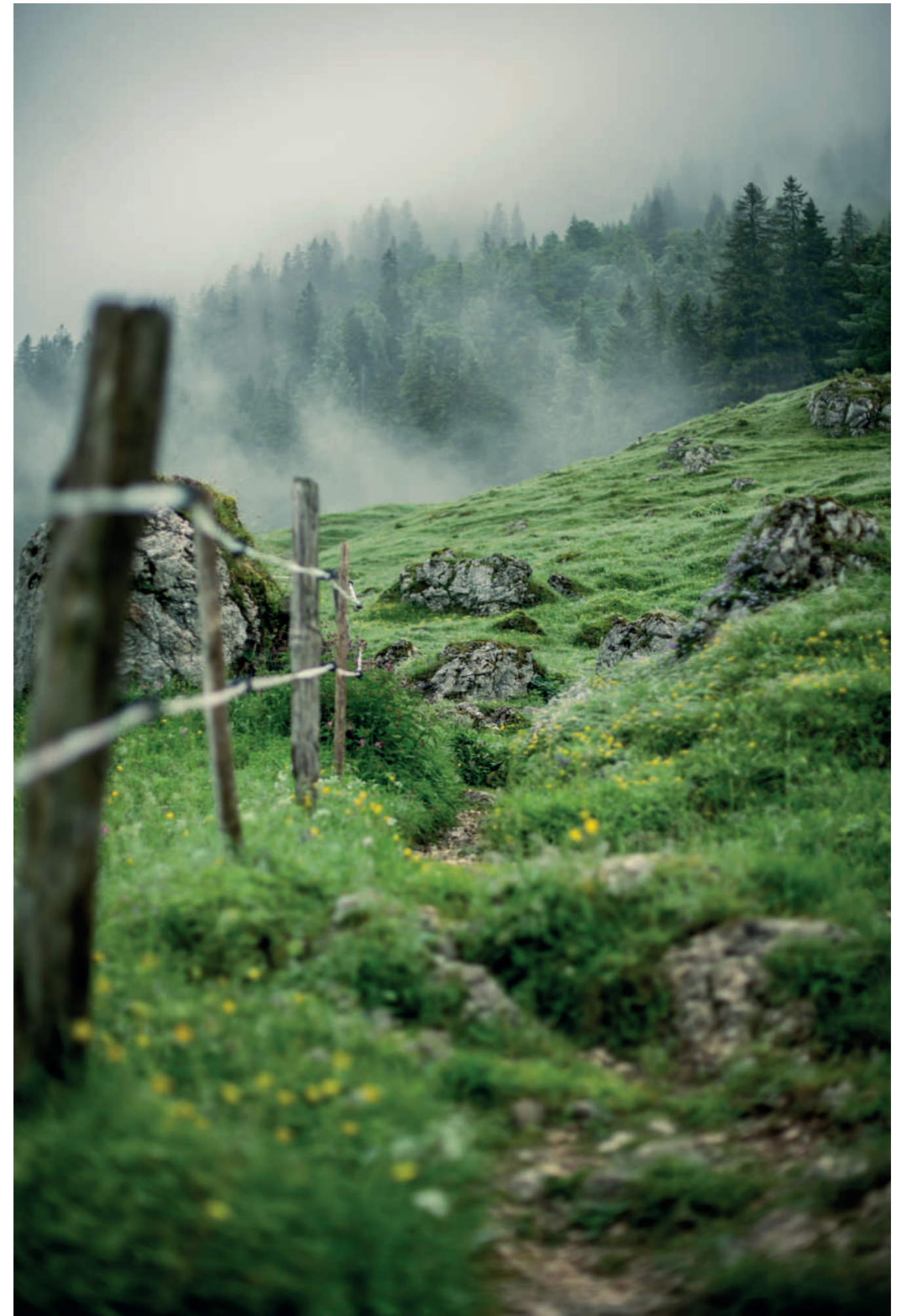



1<sup>ST</sup> UTMB 2019

1<sup>ST</sup> UTWT 2018 & 2019

1<sup>ST</sup> TRANSGRANCANARIA  
2017 - 2020



# PAU CAPELL IS A CLICKSTARTER



MICRO TRAIL RACE

FAST  
•  
LIGHT  
•  
PRECISE

**MICRO TRAIL RACE** 649 2587 Reorder Model 2021



Längen Length 110-135 cm  
 Packmaß Pack size 37 cm (120 cm)  
 Gewicht Weight 175 g (120 cm)  
 Material Material Carbon (HRC max) Ø 16 / 14 mm



**MICRO RCM SUPERLIGHT** 650 25861

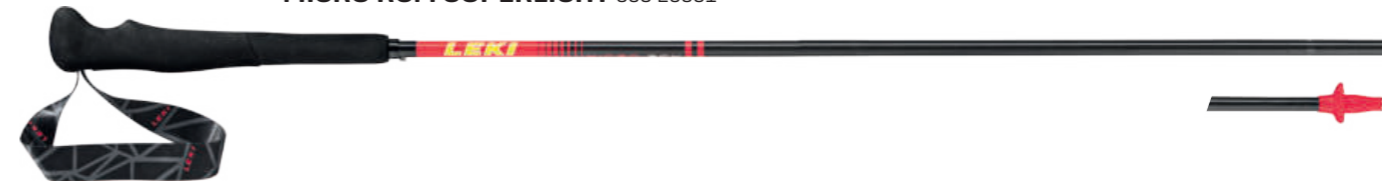

Längen Length 110-135 cm  
 Packmaß Pack size 36 cm (120 cm)  
 Gewicht Weight 128 g (120 cm)  
 Material Material Carbon (HRC max) Ø 14 / 12 mm



**MICRO TRAIL PRO** 649 2585 Reorder Model 2021



Längen Length 110-135 cm  
 Packmaß Pack size 37 cm (120 cm)  
 Gewicht Weight 195 g (120 cm)  
 Material Material Carbon (HRC) Ø 16 / 14 mm



**MICRO TRAIL PRO** 650 25852



Längen Length 105-130 cm  
 Packmaß Pack size 37 cm (120 cm)  
 Gewicht Weight 193 g (120 cm)  
 Material Material Carbon (HRC) Ø 16 / 14 mm



**MICRO FLASH CARBON** 651 25821



Längen Length 105-130 cm  
 Packmaß Pack size 37 cm (120 cm)  
 Gewicht Weight 192 g (120 cm)  
 Material Material Carbon (PRC 1000) Ø 16 / 14 mm



**MICRO TRAIL TA** 650 25751



Längen Length 110-130 cm  
 Packmaß Pack size 37 cm (120 cm)  
 Gewicht Weight 220 g (120 cm)  
 Material Material Aluminium (HTS 6.5) Ø 16 / 14 mm



LUIS ALBERTO HERNANDO ALZAGGA (ESP)

3X CHAMPION  
 SKYRUNNING WORLD SERIES

1<sup>ST</sup> CCC 2019

2<sup>ND</sup> UTMB 2015

1<sup>ST</sup> TRANSVULCANIA 2016



Photo © Alexis Berg

TRAIL RUNNING  
 FOLDING | FIXED LENGTH

TRAIL RUNNING  
 FOLDING | FIXED LENGTH

**MICRO TRAIL VARIO 649 2674**



Längen Length 100-120 cm  
 Packmaß Pack size 42 cm  
 Gewicht Weight 195 g  
 Material Material Carbon (PRC 1000) Ø 16 / 14 mm



**VERTICAL K 649 2592**



Längen Length 110-140 cm  
 Gewicht Weight 135 g (120 cm)  
 Material Material Carbon (HRC max) Ø 16 mm



**MICRO TRAIL VARIO 649 2675**



Längen Length 110-130 cm  
 Packmaß Pack size 42 cm  
 Gewicht Weight 202 g  
 Material Material Carbon (PRC 1000) Ø 16 / 14 mm



TRAIL RUNNING  
 FOLDING POLES VARIO



PABLO VILLA GONZALEZ (ESP)

1<sup>ST</sup> TRANSGRANCANARIA 2020

1<sup>ST</sup> TDS 2019

Photo @ Jordi Saragossa

TRAIL RUNNING  
 FIXED LENGTH



**EASY • COMFORTABLE • ENJOYABLE**  
PACEMAKER LITE



weight: 150 g [115 cm]  
length: 100 - 130 cm  
material: carbon [PRC 850]; Ø 14 mm



**PACEMAKER LITE** 650 25501 / 650 25502



Längen Length 100-130 cm  
 Gewicht Weight 150 g (115 cm)  
 Material Material Carbon (PRC 850)  
 Ø 14 mm



**FLASH CARBON** 650 25601 Reorder Model 2021



Längen Length 100-130 cm  
 Gewicht Weight 153 g (115 cm)  
 Material Material Carbon (PRC 700)  
 Ø 16 mm



**PASSION** 649 2525



Längen Length 100-120 cm  
 Gewicht Weight 167 g (115 cm)  
 Material Material Carbon (CC 600)  
 Ø 16 mm



**RESPONSE** 650 25201 Reorder Model 2021



Längen Length 100-130 cm  
 Gewicht Weight 190 g (115 cm)  
 Material Material Aluminium (HTS 6.0)  
 Ø 16 mm



NORDIC WALKING  
 SPEED TIP | FLEX TIP

NORDIC WALKING

**MICRO FLASH CARBON** 651 25821



Längen Length 105-130 cm  
 Packmaß Pack size 37 cm (120 cm)  
 Gewicht Weight 192 g (120 cm)  
 Material Material Carbon (PRC 1000)  
 Ø 16 / 14 mm



**SMART PACEMAKER LITE** 650 25351



Längen Length 100-130 cm  
 Gewicht Weight 165 g (115 cm)  
 Material Material Carbon (PRC 850)  
 Ø 14 mm



**SMART FLASH** 650 25401



Längen Length 100-130 cm  
 Gewicht Weight 175 g (115 cm)  
 Material Material Carbon (PRC 700)  
 Ø 16 mm



**SMART SUPREME** 649 2542



Längen Length (96) 100-130 cm  
 Gewicht Weight 225 g  
 Material Material Aluminium (HTS 6.0)  
 Ø 16 / 14 mm



**SMART RESPONSE** 650 25281 Reorder Model 2021



Längen Length 100-130 cm  
 Gewicht Weight 195 g (115 cm)  
 Material Material Aluminium (HTS 6.0)  
 Ø 16 mm



NORDIC WALKING  
 FOLDING | FIXED LENGTH

NORDIC WALKING  
 SMART TIP 2.0



NORDIC WALKING  
VARIO

NORDIC WALKING  
VARIO

**TRAVELLER CARBON** 650 26031



Längen Length (66) 90-130 cm  
Gewicht Weight 195 g  
Material Material Carbon (PRC 1000)  
Ø 16 / 14 / 12 mm



**SPIN SHARK SL** 650 26141



Längen Length (96) 100-130 cm  
Gewicht Weight 210 g  
Material Material Aluminium (HTS 5.5)  
Ø 16 / 14 mm



**INSTRUCTOR LITE** 650 26341



Längen Length (91) 100-125 cm  
Gewicht Weight 190 g  
Material Material Aluminium (HTS 6.5) | Carbon Composite (CC 600)  
Ø 14 / 12 mm



**SPIN** 650 26161 Reorder Model 2021



Längen Length (97) 100-130 cm  
Gewicht Weight 218 g  
Material Material Aluminium (HTS 5.5)  
Ø 16 / 14 mm



**TRAVELLER ALU** 650 26011 Reorder Model 2021



Längen Length (66) 90-130 cm  
Gewicht Weight 225 g  
Material Material Aluminium (HTS 6.5)  
Ø 16 / 14 / 12 mm



**WALKER XS** 650 26531



Längen Length (71) 80-110 cm  
Gewicht Weight 185 g  
Material Material Aluminium (HTS 6.0)  
Ø 14 / 12 mm





SKI ROLLER

SKI ROLLER  
FIN VARIO

**XTA VARIO** 650 31851



Längen Length 145-165 cm  
155-175 cm  
Gewicht Weight 277 g (155 cm)  
Material Material Aluminium (HTS 6.5)  
Ø 16 / 18 mm (+ 9 mm)



**XTA VARIO JUNIOR** 650 31841



Längen Length 125-145 cm  
Gewicht Weight 240 g  
Material Material Aluminium (HTS 6.5)  
Ø 14 / 16 mm (+ 9 mm)



**PRC MAX** 643 3131



Längen Length grip sep.: 160 / 170 / 180  
Gewicht Weight 66 g/m  
Material Material Carbon (PRC 1000)  
Ø 16 mm (+ 9 mm)



**PRC 700** 643 3171



Längen Length grip sep.: 150 / 160 / 170  
Gewicht Weight 75 g/m  
Material Material Carbon (PRC 700)  
Ø 16 mm (+ 9 mm)





GLOVES

ACCESSORIES

LEKI  
38



GLOVES

ACCESSORIES

LEKI  
39



### NORDIC TUNE SHARK BOA®

643 910301	black-red
643 910303	black
Größen Size	6,0 - 11,0
Konstruktion Construction	Nordic Race Fit
Eigenschaften Features	Trigger Shark with The Boa® Fit System, active light construction, mf touch, Flex Cuff
Obermaterial Main Material	Softspan (80% Nylon, 20% Elastane)
Handfläche Palm Material	AX Suede (80% Polyester, 20% Polyurethane)



### NORDIC RACE SHARK

643 911301	red-yellow-black
643 911303	black
Größen Size	6,0 - 11,0
Konstruktion Construction	Nordic Race Fit
Eigenschaften Features	Trigger Shark System, active light construction, mf touch
Obermaterial Main Material	Softspan (80% Nylon, 20% Elastane)
Handfläche Palm Material	AX Suede (80% Polyester, 20% Polyurethane)



### NORDIC SLOPE SHARK

643 914301	black-red
643 914302	black
Größen Size	6,0 - 11,0
Konstruktion Construction	Nordic Slim Fit
Eigenschaften Features	Trigger Shark System, mf touch
Obermaterial Main Material	Softspan (80% Nylon, 20% Elastane)
Handfläche Palm Material	Nash (60% Nylon, 40% Polyurethane)

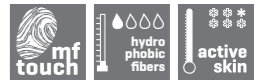

### NORDIC MOVE SHARK

649 701301	black-white
649 701302	black-yellow-white
Größen Size	6,0 / 7,0 / 8,0 / 9,0 / 10,0 / 11,0
Konstruktion Construction	Nordic Comfort Fit
Eigenschaften Features	Trigger Shark System, mf touch
Obermaterial Main Material	Softspan (80% Nylon, 20% Elastan)
Handfläche Palm Material	Amara SLT (60% Polyamide, 40% Polyurethane)



## TRIGGER SHARK 2.0 | BOA®

- ▶ Perfekte Passform
- ▶ Direkteste Verbindung
- ▶ Beste Kraftübertragung

- ▶ Perfect fit
- ▶ Closest connection
- ▶ Best power transmission





### NORDIC SLOPE

643 917301	black-white-graphite
Größen Size	6,0 - 11,0
Konstruktion Construction	Nordic Slim Fit
Eigenschaften Features	Wrist strap
Obermaterial Main Material	Softspan LT (90% Polyester, 10% Elastane)
Handfläche Palm Material	Silicone Nash SLT (55% Nylon, 45% Polyurethane)



### NORDIC SKIN

643 919301	black-red-graphite
Größen Size	6,0 - 11,0
Konstruktion Construction	Nordic Slim Fit
Obermaterial Main Material	Softspan LT (90% Polyester, 10% Elastane)
Handfläche Palm Material	Nash SLT (55% Nylon, 45% Polyurethane)



### INNER GLOVE MF TOUCH

649 814301	black
Größen Size	6,0 - 11,0
Konstruktion Construction	Comfort Fit
Eigenschaften Features	mf touch
Obermaterial Main Material	Stretch Fleece (92% Polyester, 8% Elastane)
Handfläche Palm Material	Stretch Fleece (92% Polyester, 8% Elastane)



### NORDIC BREEZE SHARK SHORT

649 703301	black-white
649 703302	black-red-white
649 703303	black-yellow-white
Größen Size	6,0 / 7,0 / 8,0 / 9,0 / 10,0 / 11,0
Konstruktion Construction	Nordic Comfort Fit
Eigenschaften Features	Trigger Shark System
Obermaterial Main Material	N-Mesh (83% Polyamide, 17% Elastane)
Handfläche Palm Material	Amara SLT (60% Polyamide, 40% Polyurethane)



### MULTI BREEZE SHORT

649 704301	black
649 704302	black-yellow-white
Größen Size	6,0 / 7,0 / 8,0 / 9,0 / 10,0 / 11,0
Konstruktion Construction	Comfort Fit
Obermaterial Main Material	N-Mesh (83% Polyamide, 17% Elastane)
Handfläche Palm Material	Amara SLT (60% Polyamide, 40% Polyurethane)





### TRAIL RUNNING CAP

3 522 240 01	white
Größen Size	Unisize
Material Material	100% Cotton



### TRAIL RUNNING TRUCKER CAP

3 523 600 05	blue-anthracite-white
Größen Size	Unisize
Material Material	Fabric: 70% Cotton, 30% Polyester Mesh: 100% Polyester



### MAKALU TRUCKER CAP

3 523 700 63	denim-orange-white
Größen Size	Unisize
Material Material	Fabric: 70% Cotton, 30% Polyester Mesh: 100% Polyester



### LOGO CAP

3 521 190 05	yellow
3 521 190 06	red
3 521 190 07	pink
Größen Size	Unisize
Material Material	98% Cotton, 2% Elastane



### CROSS TRAIL HEADBAND

3 522 180 01	black-white
3 522 180 02	mint-white
Größen Size	Unisize
Material Material	80% Polyester, 20% Elastane



### 4 SEASON HEADBAND

3 522 190 01	yellow
3 522 190 02	red
3 522 190 03	pink
Größen Size	Unisize
Material Material	80% Polyester, 20% Elastane



### MULTISCARF LEKI

3 520 301 91	yellow
3 520 301 92	red
3 520 301 93	pink
Größen Size	Unisize
Material Material	100% Polyester





### TRAIL RUNNING POLE BELT

3 683 100 01	S/M red-yellow
3 683 100 02	M/L red-yellow
Hauptmaterial Main Material Polyester, Polyamide, Elastane	



### DRINK BOTTLE

3 694 607 50	red-transparent
Volumen Volume	750 ml
Hauptmaterial Main Material LDPE (Low Density Polyethylen), PP (Polypropylen)	



### FOLDING POLE BAG

3 640 510 04	black
Länge Length	45 cm
Hauptmaterial Main Material Polyester	



### DRINKBELT

3 634 400 56	anthracite-cyan-neonyellow
3 634 400 04	anthracite-red-neonyellow
Hauptmaterial Main Material Polyester	



### NORDIC WALKING POLE BAG

3 643 101 06	red
3 643 101 03	black
Länge Length	160 cm
Hauptmaterial Main Material Polyester	



### DRINKBELT THERMO

3 634 300 06	
Details Details	4 h warm
Volumen Volume	1 l

### TRAVEL TROLLEY

3 636 300 06	black
Größe Size	80 x 35 x 40 cm
Volumen Volume	110 l
Material Material	60% 600D Polyester / 40% 400D Polyester



### TREKKING POLE BAG

3 643 000 06	red
3 643 001 03	black
Länge Length	93 cm
Hauptmaterial Main Material Polyester	



### TRAINER POLE BAG SMALL

3 607 000 06	red
Länge Length	140 cm
Details Details	für 2 Paar Stöcke for 2 pairs
Hauptmaterial Main Material Polyester	



### TRAVEL SPORTS BAG WCR

3 632 510 06	black
Größe Size	70 x 35 x 35 cm
Volumen Volume	85 l
Material Material	40% 600D Polyester / 60% 400D Polyester



### ALPINE / NORDIC WALKING POLE BAG

3 605 200 06	big for 15 pairs of poles
Länge Length	140 cm
Material Material	600D Polyester PVC beschichtet + Tarpaulin



### NORDIC SHARK 2.0

8 361 1414 0 02    **Ø 14 mm** white  
 8 361 1414 0 12 00-1    **Ø 14 mm** neonyellow  
 8 361 1616 0 02    **Ø 16 mm** white  
 8 361 1616 0 12    **Ø 16 mm** neonyellow



### TRIGGER SHARK ACTIVE STRAP

8 865 00 1 56    **S-M-L** silver- black  
 8 865 10 1 56    **M-L-XL** silver- black



### TRIGGER SHARK FRAME STRAP MESH

8 867 101 26    **S-M-L** anthracite  
 8 867 201 26    **M-L-XL** anthracite  
 8 867 101 12    **S-M-L** neonyellow  
 8 867 201 12    **M-L-XL** neonyellow  
 8 867 101 04    **S-M-L** red  
 8 867 201 04    **M-L-XL** red



### TRIGGER SHARK STRAP

8 863 311 06    **M-L-XL** red  
 8 863 301 25    **S-M-L** silver-black  
 8 863 311 25    **M-L-XL** silver-black



### NORDIC CORTEC TRIGGER 1 V2

8 345 16 16 0 03 00    **Ø 16 mm** brown-black



### TRIGGER 1 V2 STRAP

8 862 10 1 25    **S-M-L** silver-black  
 8 862 11 1 25    **M-L-XL** silver-black



### AERGON THERMO / LSS

8 300 18 18 0 81 30    **Ø 18 mm**  
 8 301 16 16 1 81 31    **Ø 16 mm**



### AERGON THERMO / SKIN STRAP 3.0

8 300 18 18 1 02 65    **Ø 18 mm**  
 8 300 16 16 0 02 58    **Ø 16 mm**



### AERGON 2K CORTEC

8 302 18 18 0 09 30    **Ø 18 mm**  
 8 304 16 16 1 09 31    **Ø 16 mm**



### AERGOMED 2K SOFT

8 350 18 18 0 82 29    **Ø 18 mm**



### SPEED LOCK LEVER INCL. KNURLED WHEEL

8 806 011 \*03    **Ø 20 / 18 mm**  
 8 806 001 00 / \*02    **Ø 18 / 16 mm**  
 8 806 101 00 / \*02    **Ø 16 / 14 mm**  
 8 806 201 00 / \*02    **Ø 14 / 12 mm**



### SPEED LOCK PLUS LEVER

8 806 301 \*02 / \*03    **Ø 18 / 16 mm**  
 8 806 401 \*02 / \*03    **Ø 16 / 14 mm**  
 8 806 501 \*02 / \*03    **Ø 14 / 12 mm**



### SPEED LOCK 2 LEVER INCL. KNURLED WHEEL

8 806 601 \*02 / \*03    **Ø 18 / 16 mm**  
 8 806 701 \*02 / \*03    **Ø 16 / 14 mm**  
 8 806 801 \*02 / \*03    **Ø 14 / 12 mm**

\*colorcode: 02 - white 03 - black



### HÜLSE V2 SLEEVE V2

8 809 601 02    **Ø 14 / 12 mm**  
 8 809 501 02    **Ø 16 / 14 mm**

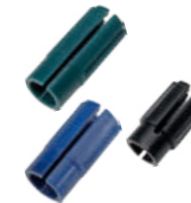

### SLS KLEMMHÜLSE SLS SLIT DOWEL

8 807 141 08    **Ø 14 mm**  
 8 807 161 05    **Ø 16 mm**  
 8 807 181 03    **Ø 18 mm**



### HÜLSE SLEEVE

8 809 101 03    **Ø 14 / 12 mm**  
 8 809 201 03    **Ø 16 / 14 mm**  
 8 809 301 03    **Ø 18 / 16 mm**



### AERGON PHOTOADAPTER

8 836 000 56



### TRIGGER V MESH STRAP

8 865 711 04    **OSFA** grey



### TRIGGER V STRAP

8 865 621 56    **OSFA** anthracite



**\*MULTI SYSTEM**

Original Silent Spike Pad und Power Grip Pad mit Adaptern. Passend für diverse Fremdfabrikate. Original Silent Spike Pad and Power Grip Pad with adapters. Fitting for various competitive brands.



Querschnitt Hülse rund  
Cross section case round

Querschnitt Hülse spitz  
Cross section case pointed

**SILENT SPIKE PAD**

8 823 201 03 1 PAAR / 1 PAIR \*\*  
8 823 203 03 25 PAAR / 25 PAIR

**SILENT SPIKE PAD MULTI\***

8 823 101 03 1 PAAR / 1 PAIR \*\*

**POWER GRIP PAD**

8 824 201 03 1 PAAR / 1 PAIR \*\*  
8 824 202 03 50 PAAR / 50 PAIR

**POWER GRIP PAD MULTI\***

8 824 101 03 1 PAAR / 1 PAIR \*\*



**SILENT SPIKE PAD TREKKING**

8 825 001 03 1 PAAR / 1 PAIR \*\*  
8 825 002 03 25 PAAR / 25 PAIR



**RUBBER TIP WALKING**

8 818 001 03 1 PAAR / 1 PAIR \*\*  
8 818 100 03 50 PAAR / 50 PAIR



**RUBBER TIP TREKKING**

8 821 101 04 1 PAAR / 1 PAIR \*\*  
8 821 102 03 25 PAAR / 25 PAIR



**SMART TIP PAD NORDIC WALKING**

8 826 101 03 1 PAAR / 1 PAIR \*\*

Online Video  
[www.leki.com/alte-videos](http://www.leki.com/alte-videos)



**SMART TIP PAD 2.0 NORDIC WALKING**

8 828 101 03 1 PAAR / 1 PAIR \*\*



Changeable pad - no tools needed

\*\* Mindestbestellmenge / minimum order quantity 5 PAAR / 5 PAIR



**NORDIC WALKING BASKET**

8 564 001 03 Ø 40 mm



**TREKKING BASKET**

8 565 001 03 Ø 50 mm



**TREKKING BASKET 2.0**

8 510 001 03 Ø 45 mm



**TOURING BASKET**

8 575 001 03 Ø 95 mm



**FLEX TIP**

8 786 101 03 short  
8 785 201 03 long



**DSS TIP**

REPLACEMENT TIP ONLY FITS ON DSS POLES

8 766 001 03 Ø 14 mm  
8 766 101 03 Ø 12 mm



**TRAIL TIP**

8 716 001 03 Ø 9 mm black  
8 716 001 12 Ø 9 mm neonyellow  
8 716 001 14 Ø 9 mm neonred



**TRAIL RUNNING TIP XT**

8 718 001 05 Ø 9 mm blue  
8 718 001 12 Ø 9 mm neonyellow  
8 718 001 14 Ø 9 mm neonred  
8 718 001 17 Ø 9 mm lime  
8 718 001 91 Ø 9 mm mint  
8 718 001 95 Ø 9 mm rhodamine red



**NORDIC WALKING SPEED TIP**

8 589 801 03



**NORDIC BLADING SPEED TIP**

8 589 802 12 Ø 9 mm  
8 589 801 12 Ø 8 mm



**FIN VARIO INCL. SLEEVE FOR Ø 8+9 MM**

8 500 101 12 Basket S / M Ø 8+9 mm neon  
8 500 201 12 Basket M / L Ø 8+9 mm neon  
8 500 301 12 Basket L / XL Ø 8+9 mm neon  
8 500 401 12 Rollertip Ø 8+9 mm neon



**TIP SAFER**

8 814 001 01



**HOT GLUE**

8 799 200 00 5 Stück 5 pcs

ACCESSORIES  
SPAREPARTS

ACCESSORIES  
SPAREPARTS

# TECHNOLOGY

## MATERIALINDEX ROHRE

Das Material und deren Qualität ist eines der wichtigsten Komponenten für Leichtigkeit, Steifigkeit und Performance.

### Carbon

HRC steht für Highest Racing Carbon. Für die leichtesten Stöcke gibt es HRC Max und HRC.

PRC bedeutet Performance Racing Carbon. Hier prägen 3 Qualitätslevels die Kollektion: PRC 1000, PRC 850 und PRC 700.

Mit CC beschreibt LEKI die Kategorie Carbon Composite mit dem Level CC 600.

### Aluminium

HTS (Heat Treated Shaft) ist die höchste Qualität bei den LEKI Aluminium Modellen mit 3 Levels: HTS 6.5, HTS 6.0 und HTS 5.5.

## MATERIAL INDEX SHAFTS

The material and its quality is one of the most important components for lightness, stiffness and performance.

### Carbon

HRC means Highest Racing Carbon. The lightest poles of this top level are split into HRC Max and HRC.

PRC means Performance Racing Carbon and is split into 3 quality levels: PRC 1000, PRC 850 and PRC 700.

CC means Carbon Composite with the level CC 600.

### Aluminium

HTS (Heat Treated Shaft) is the highest quality in the LEKI aluminium line. 3 levels: HTS 6.5, HTS 6.0 and HTS 5.5.

# CROSS SHARK

COMPATIBLE WITH



Der Cross Shark bietet dir die Geschwindigkeit des Shark Systems und die Unterstützung eines Hiking-Griffs.

- Dynamische und komfortable Konstruktion für speedorientiertes Berggehen.
- Kontrollierte Führung durch Funktionsschleufe in Verbindung mit ergonomischen Griffzonen.
- Fixierte und sichere Position der Hand am Griff.
- Sekundenschnelles Fixieren und Lösen der Schlaufe.

The Cross Shark offers you the speed of the Shark system and the support of a hiking grip.

- Dynamic and comfortable construction for speed-oriented movement in the mountain.
- Controlled guidance through the functional strap in conjunction with ergonomic grip zones.
- Fixed and secure position of the hand on the grip.
- Simple handling, fast adjustment.

Le Cross Shark offre la rapidité du système Shark, ajouté au support offert par une poignée conçue pour la randonnée.

- Construction dynamique et confortable pour se mouvoir en montagne dans une optique de rapidité.
- Parfait contrôle de la poussée au travers d'une dragonne fonctionnelle et de zones offrant une préhension ergonomique.
- Position de la main fixe et assurée sur la poignée.
- Prise en main simplifiée, réglage rapide.

L'impugnatura Cross Shark offre la velocità del sistema Shark e il sostegno di un' impugnatura da trekking.

- Costruzione dinamica e confortevole per passeggiate in montagna orientate alla velocità.
- Guida controllata grazie al lacciolo funzionale che fa da collegamento alle ergonomiche zone d'impugnatura.
- Fissaggio e sicura posizione della mano all'impugnatura.
- Fissaggio del lacciolo semplice e rapido.



## TRIGGER SHARK FRAME STRAP MESH

- Atmungsaktive Trigger Shark Schlaufe aus Mesh-Material
- Optimierte Passform: Umschließt die Hand sicher & fest
- Breite Auflagefläche

- Breathable Trigger Shark Strap made of mesh
- Optimized fit: encloses the hand securely
- Large support area

- Dragonne en filet respirant Trigger Shark
- Nouveau patron : enrobe fermement la main
- Forme élargie

- Trigger Shark lacciolo traspirante in materiale mesh
- Calzata ottimizzata: avvolge la mano in modo sicuro e compatto
- Larga ed ampia area di superficie

## BEST TREKKING GRIP

- Große AERAGONomische Stützfläche am Griffkopf
- Kantenfreie Außenform ermöglicht variable Greifmöglichkeiten
- Biotec 2 - Schalen Hohlraumtechnologie sorgt für absolute Leichtigkeit
- Large AERAGONomic support area on top of the grip for secure hold
- An edgeless outer shape offers a variety of gripping options
- Biotec 2 - Extremely lightweight shell cavity construction

- Large zone AERAGONomique de support sur le sommet de la poignée, pour une prise en main plus sûre
- Forme toute arrondie, sans aucun angle, permettant de nombreuses options de prise en main
- Biotec 2 - le pommeau Aergon est creux, pour un poids extrêmement léger
- Grande superficie d'appoggio AERAGONomica sulla testa dell'impugnatura con Softpad
- Forma esterna senza spigoli permette le più svariate possibilità di presa
- Biotec 2 - guscio, la tecnologia del vuoto provvede ad una leggerezza assoluta

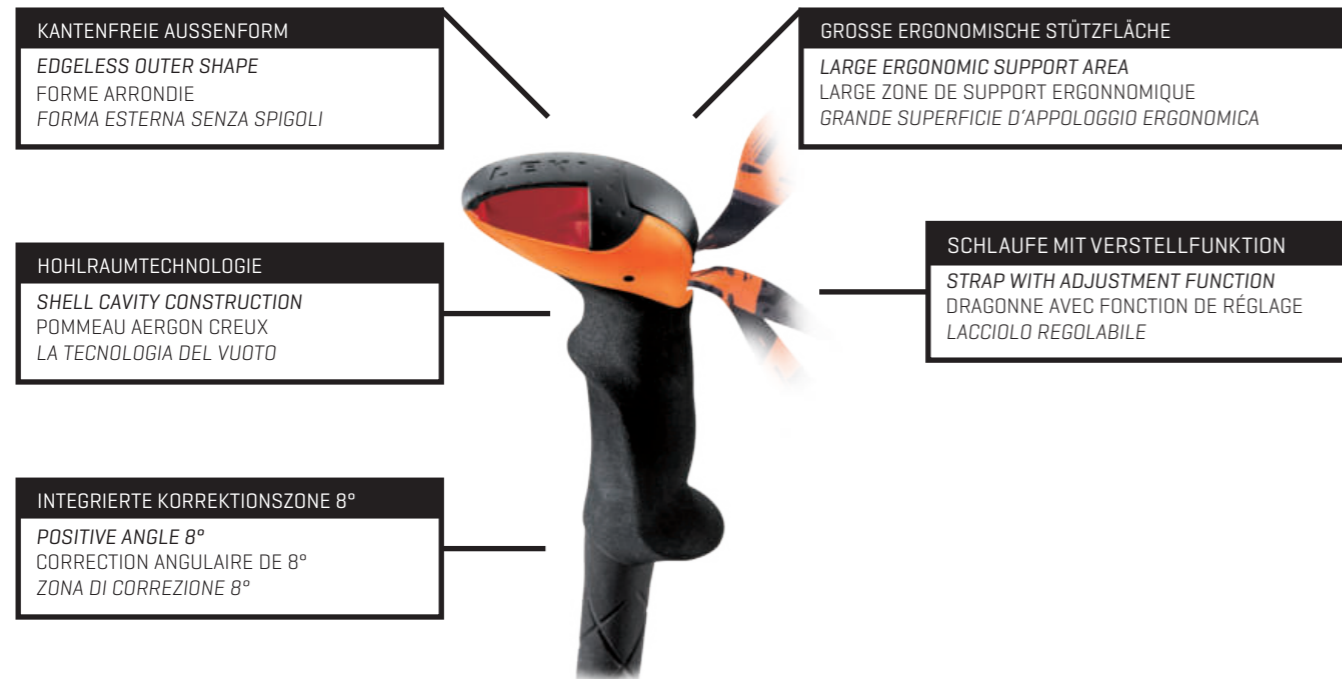

## PA SAFETY SYSTEM

### Schlaufe mit Verstellfunktion

- Einfach zu verstellen

### Strap with adjustment function

- Easy to adjust

### Dragonne avec fonction de réglage

- Maintien assuré

### Lacciolo regolabile

- Regolazione semplice



## TREKKING GRIP

- Abgerundete Stützfläche für ein angenehmes bergab gehen
- PA Safety System
- Bewährter Aergon-Griff nachempfunden
- Round top for a comfortable use in downhill
- PA Safety System
- Inspired by the well-proven Aergon design

- Extrémité arrondie pour une utilisation confortable en descente
- Système PA Safety
- Inspiré du très éprouvé concept Aergon
- Superficie d'appoggio arrotondata per un comodo utilizzo in discesa
- PA Safety System
- Forma collaudata basata sull'impugnatura AERAGON



# FOLDING POLES MICRO VARIO SYSTEM

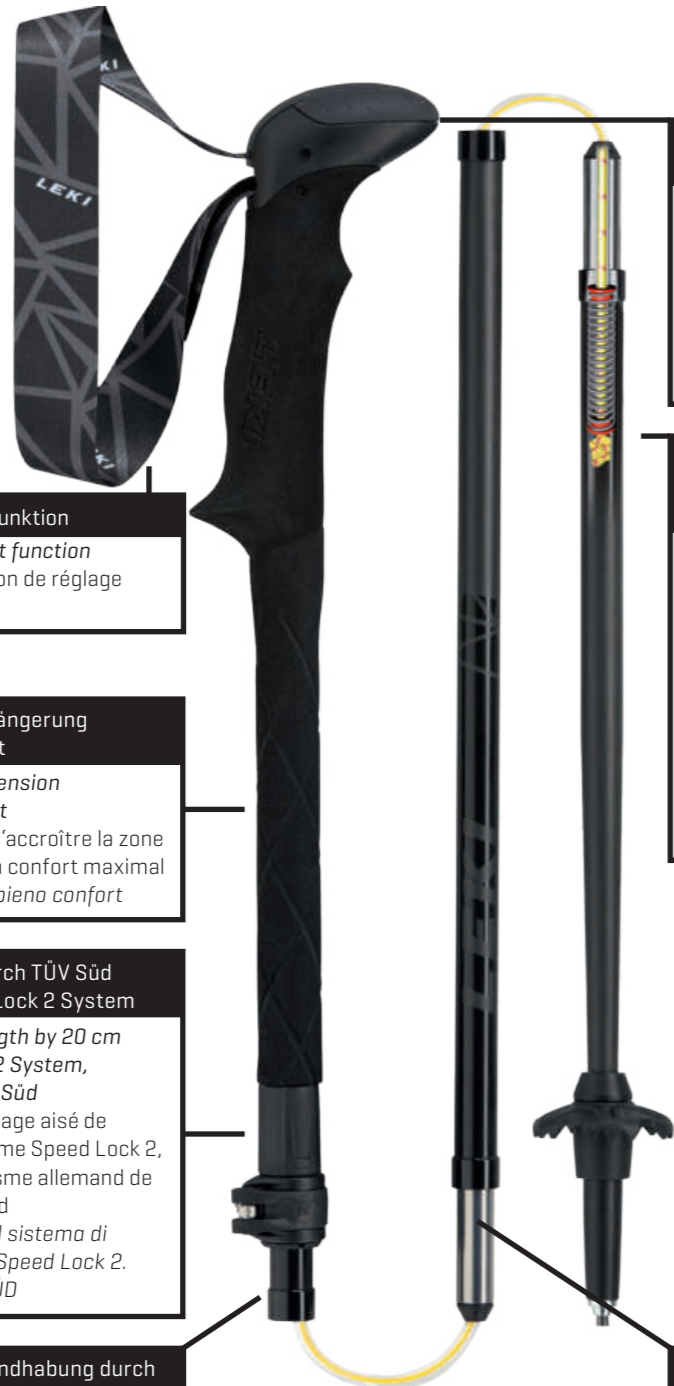

- Schlaufe mit Verstellfunktion
- Strap with adjustment function
- Dragonne avec fonction de réglage
- Lacciolo regolabile

- Griffige Mid-Griffverlängerung für höchsten Komfort
- Non-slip mid grip extension for maximum comfort
- Le manchon permet d'accroître la zone de préhension pour un confort maximal
- Prolunga-Mid per un pieno confort

- 20 cm verstellbar durch TÜV Süd zertifiziertes Speed Lock 2 System
- Smoothly change length by 20 cm with the Speed Lock 2 System, approved by the TÜV Süd
- Une possibilité de réglage aisé de 20 cm grâce au système Speed Lock 2, approuvé par l'organisme allemand de normalisation TÜV Süd
- 20 cm regolabili con il sistema di regola zione esterna Speed Lock 2. Certificato dal TÜV SÜD

- **CLD:** Komfortable Handhabung durch intuitiven Auszugsmechanismus
- **CLD:** Comfortable handling due to intuitive adjustment mechanism
- **CLD:** Utilisation aisée grâce au mécanisme intuitif d'ajustement
- **CLD:** Gestione confortevole e maneggevolezza grazie all'intuitivo meccanismo di estrazione

- Verstärktes, filigranes High-Performance-Spannseil mit einer robusten PE Ummantlung, welche lebenslangen Schutz der Fasern bietet
- Filigrane high performance tensioning rope reinforced with sturdy PE coating for lifelong protection of the fibers
- Cordelette renforcée haute performance, durablement enduite de polyéthylène pour une protection des fibres à vie
- Cavo sottile "High-Performance"rinforzata. Rivestimento robusto di plastica (PE) offre una protezione delle fibre a vita

- Aergon Griff mit Hohlraumtechnologie für absolute Leichtigkeit
- Aergon Grip in shell cavity construction for extreme lightweight
- Le pommeau de la poignée Aergon est creux, pour une légèreté extrême
- Impugnatura Aergon con la tecnologia del vuoto provvede ad una leggerezza assoluta

- Im Unterteil liegende Feder garantiert optimale Spannung und automatische Seil-Längenkompensation
- A spring in the lower shaft guarantees maximum tension and automatic rope length compensation
- Un ressort présent dans la section inférieure du bâton optimise la tension de la corde et ajuste automatiquement la longueur
- La molla posizionata nella sezione bassa (terminale) garantisce un'ottima tensione e compensazione delle lunghezze

- Spezielle Aluminiumhülsen schützen die hochmodularen Carbonfasern und perfektionieren die Verbindung der einzelnen Segmente
- Special aluminium sleeves protect the high modular carbon fibers and guarantee a perfect connection of the sections
- Des manchons en Aluminium protègent la fibre de carbone à haut module et garantissent une cohésion parfaite entre les sections
- Speciali manicotti in alluminio proteggono le fibre di carbonio a elevata modularità e perfezionano le giunzioni dei singoli segmenti.

# FOLDING MECHANISMS



## CLD CORE LOCKING DEVICE

- Komfortable Handhabung durch intuitiven Auszugsmechanismus
- Schlanke, gewichtssparende Konstruktion für ein elegantes Stockdesign
- System im Stockinneren vor äußeren Einflüssen geschützt
- Comfortable handling due to intuitive adjustment mechanism
- Slim lightweight construction for an elegant pole design
- System inside the pole - well protected against external influences
- Utilisation aisée grâce au mécanisme intuitif d'ajustement
- Construction fine et légère, pour un bâton au design élégant
- Système interne, parfaitement protégé des facteurs extérieurs
- Gestione confortevole e maneggevolezza grazie all'intuitivo meccanismo di estrazione
- Costruzione sottile con peso ridotto per un design elegante del bastone
- Sistema all'interno della canna protetto da influenze esterne



## ELD EXTERNAL LOCKING DEVICE

- Einfach zu bedienen - per Knopfdruck wird die Stockspannung gelöst
- Spezielle Konstruktion für noch mehr Stabilität und Sicherheit
- Easy to handle - a push button releases the pole tension
- Special construction for even more stability and safety
- Facilité d'utilisation - un bouton poussoir détend la cordelette maintenant le bâton déplié
- Construction spéciale pour une stabilité et une sécurité accrues
- Facile da usare - premendo il pulsante si allenta la tensione del bastone
- Costruzione speciale per garantire ancora più stabilità e sicurezza



## PB PUSH BUTTON

- Push Button Release Mechanismus zum schnellen, einfachen Auf- und Abbau
- Bewährtes System in Outdoor Ausrüstungen
- Push Button Release Mechanism for fast and simple assembly and collapse
- Approved system in outdoor gears
- Utilisation d'un bouton poussoir pour un pliage et dépliage aisés
- Système reconnu dans le monde de l'Outdoor
- Meccanismo Push Button Release per un facile e veloce montaggio e smontaggio
- Sistema collaudato nell'attrezzatura Outdoor

# TRIGGER S 2.0 SHARK

## BEST NORDIC SYSTEM

- Sekundenschnelles Fixieren und Lösen der Schlaufe
- Einfachste Handhabung, zuverlässige Verbindung
- Höchster Komfort, maximale Kraftübertragung
- Click in and out in seconds
- Simple handling, reliable connection
- Highest comfort, ideal power transmission

- *Prise en main aisée, ajustement rapide*
- *Adaptabilité précise et parfaite, contrôle optimal*
- *Confort maximal, transmission idéale de l'effort*
- *Fissaggio del lacciolo semplice e rapido*
- *Montaggio perfetto e preciso, guida ottimale*
- *Massimo comfort, trasmissione ideale*

## A POWERFUL CONNECTION

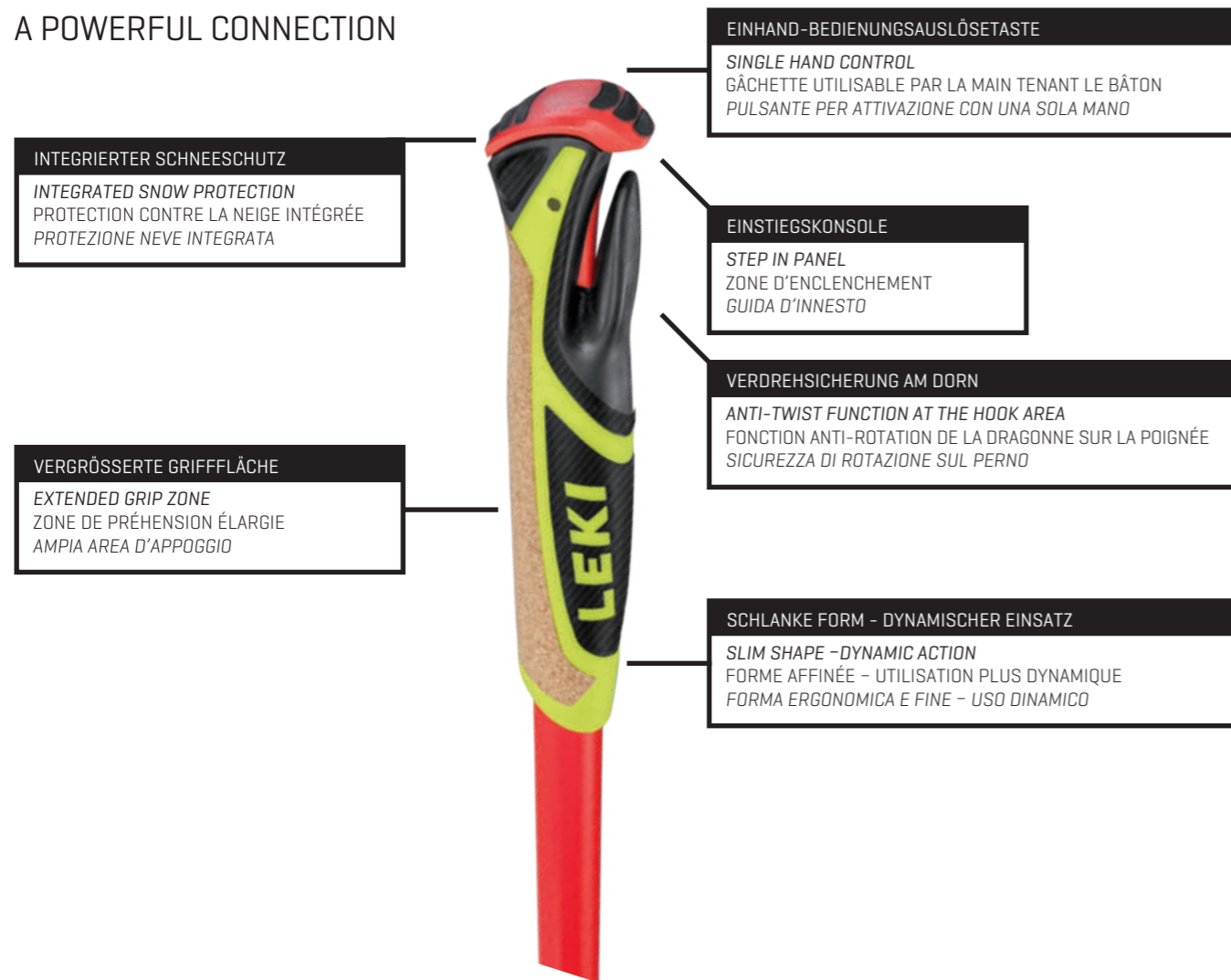

## TRIGGER SHARK FRAME STRAP MESH DEPENDING ON MODEL



- Atmungsaktive Trigger Shark Schlaufe aus Mesh-Material
- Optimierte Passform: Umschließt die Hand sicher & fest
- Breite Auflagefläche
- Breathable Trigger Shark Strap made of mesh
- Optimized fit: encloses the hand securely
- Large support area

- Dragonne en filet respirant Trigger Shark
- Nouveau patron : enrobe fermement la main
- Forme élargie
- Trigger Shark lacciolo traspirante in materiale mesh
- Calzata ottimizzata: avvolge la mano in modo sicuro e compatta
- Larga ed ampia area di superficie

## TRIGGER SHARK GLOVE - PERFECT COMBINATION

- Perfektioniert das Trigger Shark System
- Trigger S Loop - klein, stark, flexibel - zuverlässige Verbindung
- Integrierter Powerframe - perfekt und individuell auf jede Größe eingebaut
- Makes the Trigger S Shark System perfect
- Trigger S Loop - small, strong, flexible - reliable connection
- Integrated Powerframe - perfectly adapted to each individual size

- *Le système Trigger S Shark poussé à la perfection:*
- *La boucle Trigger S - compacte, solide et souple- une connection fiable*
- *Powerframe intégré - une adaptation parfaite à chaque individu*
- *Perfezionamento del Sistema Trigger S Shark System*
- *Trigger S Loop - piccola, robusto, flessibile - collegamento affidabile*
- *Powerframe integrato - installato in modo perfetto ed individuale per ogni misura*

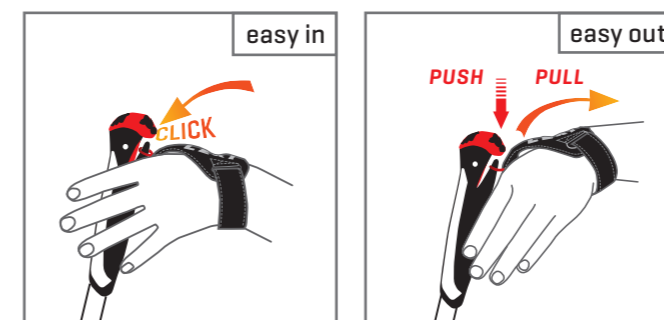

# EXTERNAL LOCKING SYSTEMS

- Extrem schnelles Verstellen und Fixieren auch mit dicken Handschuhen bei Nässe, Eis und Schnee
- Schraube mit Sicherheitsfunktion und Nachstellmöglichkeit
- *Ajustement et serrage extrêmement rapide, même avec des gants fins, quelles que soient les conditions de neige, de glace ou de pluie*
- *Vissage avec fonction sécurité et indication du sens de serrage + / -*
- *Extremely fast adjustment and fixing even whilst wearing thick gloves in rain, ice and snow*
- *Security screw with + / - indicator*
- *Regolazione e fissaggio molto rapido è possibile anche con guanti spessi e in presenza d'umidità, ghiaccio e neve*
- *Vite con funzione di sicurezza e indicatore direzione + / -*

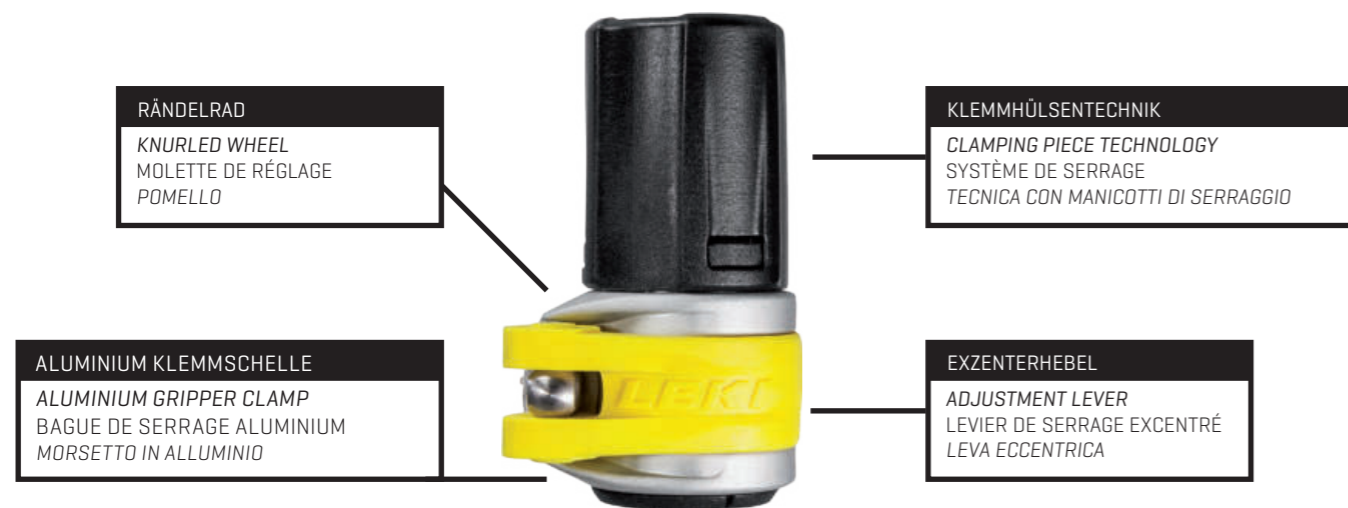

# SUPER LOCK WORLDWIDE BEST INTERNAL LOCKING SYSTEM



- Maximale Sicherheitsreserven
- Höchste Haltekraft [140 kg garantiert]
- Äußerste Rückdrehsicherheit [mehr als 360°]
- *Insuperati margini di sicurezza*
- *Massima tenuta [140 kg garantiti]*
- *Insuperabile sicurezza antisblocco [più di 360°]*
- *Maximum security reserves*
- *Highest holding force in the test > 140 kg per pole*
- *Highest locking security for highest back turn security > 360°*
- *Sécurité maximum*
- *Force de retenue la plus élevée lors de test > 140 kg*
- *Sécurité de desserrage la plus élevée > 360°*

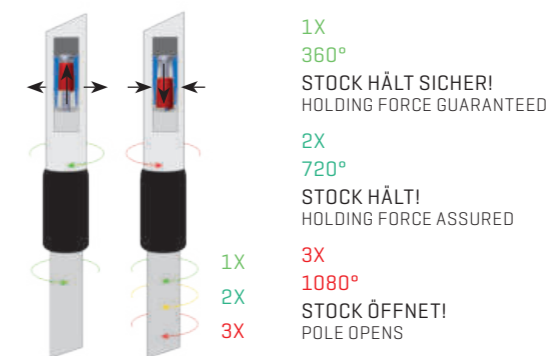

## VERSTELLSYSTEME HALTEKRAFT LOCKING SYSTEMS HOLDING FORCE

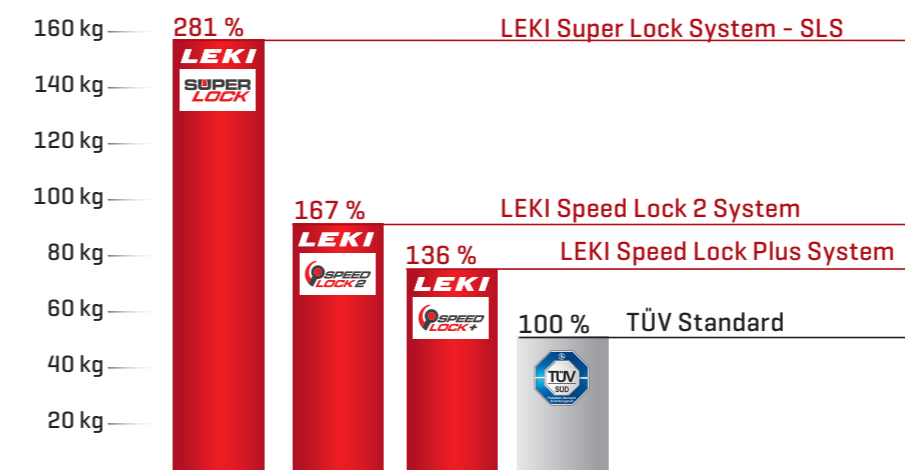

- LEKI Super Lock System - SLS**
- Maximale Haltekraft [N] bei einem Anzugsdrehmoment von 1,4 Nm
  - *Maximum holding force [N] with 1,4 Nm locking torque*
- LEKI Speed Lock System**
- Maximale Haltekraft [N] mit 3 kg Schließkraft
  - *Maximum holding force [N] with 30 N locking force*

Nur LEKI Systeme liegen weit über der TÜV Empfehlung  
Einzelheiten zum Vergleich können gerne bei der LEKI Lenhart GmbH - Karl-Arnold-Str. 30 - D-73230 Kirchheim / Teck abgerufen werden.

Only LEKI systems are much stronger than the TÜV recommendation  
Full data on the contest can be requested by contacting LEKI Lenhart GmbH - Karl-Arnold-Str. 30 - D- 73230 Kirchheim / Teck.



# DYNAMIC SUSPENSION SYSTEM



- Circa 40 % Reduzierung der Aufprall-Spitzenkräfte, entlastet Muskulatur, Gelenke und Bänder\*
- Optimale Dämpfungseigenschaften sorgen für einen kontrollierten Stockeinsatz
- Effektive, vibrationsabsorbierende Konstruktion, durch clevere Platzierung und spezielles Elastomermaterial

\* Ergebnis der Studie des Lehrstuhls für Biomechanik, Bewegungs- und Trainingswissenschaft des Instituts für Sportwissenschaft der Universität Tübingen.

- *Reduction of the peak impacts by approx. 40 % thus protecting muscles, joints and ligaments.\**
- *Optimal damping features for a controlled pole plant.*
- *Effective vibration-absorbing construction based on a clever positioning and a special elastomer.*

\* Result of a study issued by the „Lehrstuhl für Biomechanik, Bewegungs- und Trainingswissenschaft des Instituts für Sportwissenschaft der Universität Tübingen“ [Chair for Biomechanics and Kinesiology at the Institute for Sport Science of the Tübingen University].



- Réduction d'environ 40 % des impacts, pour une meilleure protection des muscles, articulations et ligaments.\*
- Caractéristiques d'amortissement optimisées pour un parfait contrôle du planter du bâton.
- Procédé d'absorption de vibrations efficace, basé sur un positionnement optimal, ainsi que l'utilisation d'un élastomère spécifique.

\* D'après une étude réalisée par la Chaire de Biomécanique et de Kinésiologie de l'Institut des Sciences Appliquées au Sport de l'Université de Tübingen.

- *Riduzione d'impatto di circa il 40 %, protegge la muscolatura, le articolazione e i legamenti \**
- *Ottimali caratteristiche di smorzamento garantiscono un controllato utilizzo ed impiego dei bastoni*
- *Costruzione efficace che assorbe le vibrazioni, grazie al posizionamento intelligente ed il materiale speciale in elastomero*

\* Risultato dello Studio del Dipartimento di Biomeccanica, Kinesiologia, Scienza Motoria e Formazione Atletica dell'Istituto di Scienza dello Sport dell'Università di Tübingen.

# SMART TIP 2.0



- Perfekt für Walker, die häufig zwischen Asphalt und Gelände wechseln
- Integrierte, ausfahrbare Hartmetallspitze mit verbesserter Geometrie, für noch mehr Halt auf nicht asphaltierten Wegen
- Sekundenschnelles Wechseln zwischen Pad- und Tip-Stellung
- Einfacher, werkzeugloser Padwechsel und verbessertes Pad Profil

- *Perfect for nordic walkers who like to switch from paved to unpaved ground and back*
- *Integrated, extendible hard metal tip with improved geometry for even more grip on non-bituminised paths*
- *Very fast switch between pad and tip position*
- *Simple, tool-less pad change and improved pad profile*

- Idéal pour les marcheurs nordiques qui alternent l'asphalte et les sentiers
- Pointe en carbure escamotable intégrée avec géométrie améliorée pour une prise plus sûre sur les chemins non goudronnés
- Changement ultrarapide entre le pad et la pointe
- Changement simple et sans outil des pads et profil amélioré

- *Ideale per chi piace cambiare il terreno durante la camminata, cambiando tra le strade asfaltate e non asfaltate*
- *Puntali in metallo duro estraibili integrati, dalla geometria migliorata, per una tenuta ancora maggiore su sentieri non asfaltati*
- *Commutazione rapidissima tra posizione pad e tip*
- *Sostituzione semplice del pad senza necessità di utensili e profilo del pad migliorato*

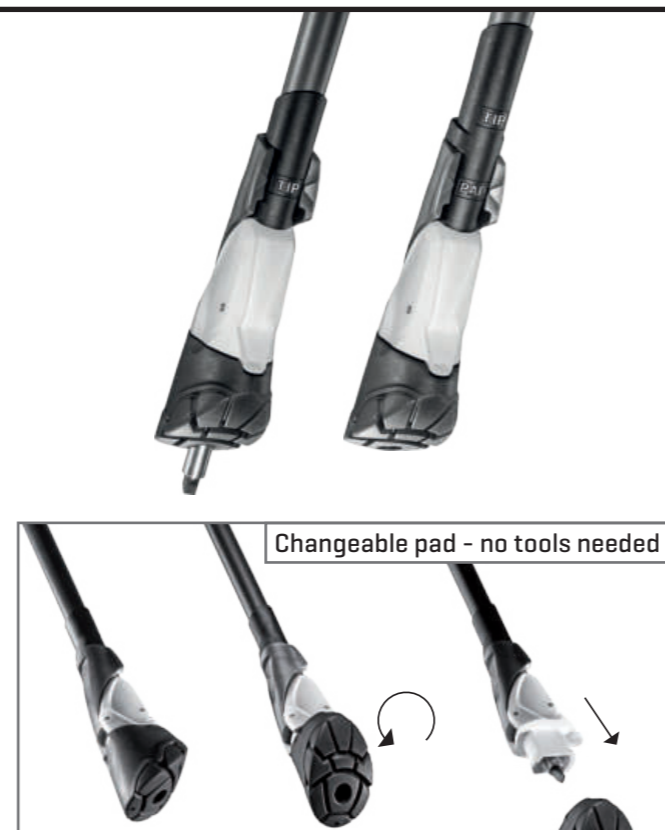

# TREKKING BASKET 2.0



- Mit jeder Flextip kompatibel
- Effektiver Einsinkschutz dank neu angepasster Größe mit Ø 45 mm
- Ansprechendes Design

- *Compatibile con ogni Flextip*
- *Efficace protezione di sprofondamento grazie alle dimensioni adattate con Ø 45 mm*
- *Design attrattivo*

- *Compatible with every Flextip*
- *Effective protection against sinking in due to increased diameter of 45 mm*
- *Attractive design*

- Compatible avec toutes les pointes Flex
- Efficacité accrue grâce à un diamètre désormais égal à 45mm
- Design attractif



# FIN VARIO



- Simple Wechseln der Tellergröße für unterschiedliche Loipen-Beschaffenheiten
- Wechsel von Winterteller auf Sommer-Rollerspizze
- Keine Unterscheidung ob 8er oder 9er Konus

- Modification facile de la taille de la rondelle pour différentes caractéristiques de ski de fond
- Passage de la rondelle d'hiver à la pointe roulante d'été
- Aucune distinction entre un cône 8 ou 9

- *Fast and easy exchange of the basket size for all kinds of track conditions*
- *Exchange from winter basket to summer rollertip*
- *Fits 8mm and 9mm cones*

- *Cambio semplice della grandezza della papera per le diverse piste, binari e realtà*
- *Cambio della papera invernale a quella estiva Rollertip*
- *Nessuna distinzione se da 8 o 9 mm di diametro del cono*

# ADJUSTABLE BASKET CHANGING SYSTEM WITH SET / KIT

SET- UND SYSTEMGEDANKE FÜR EIN VARIABLES WECHSELTELLER-SYSTEM

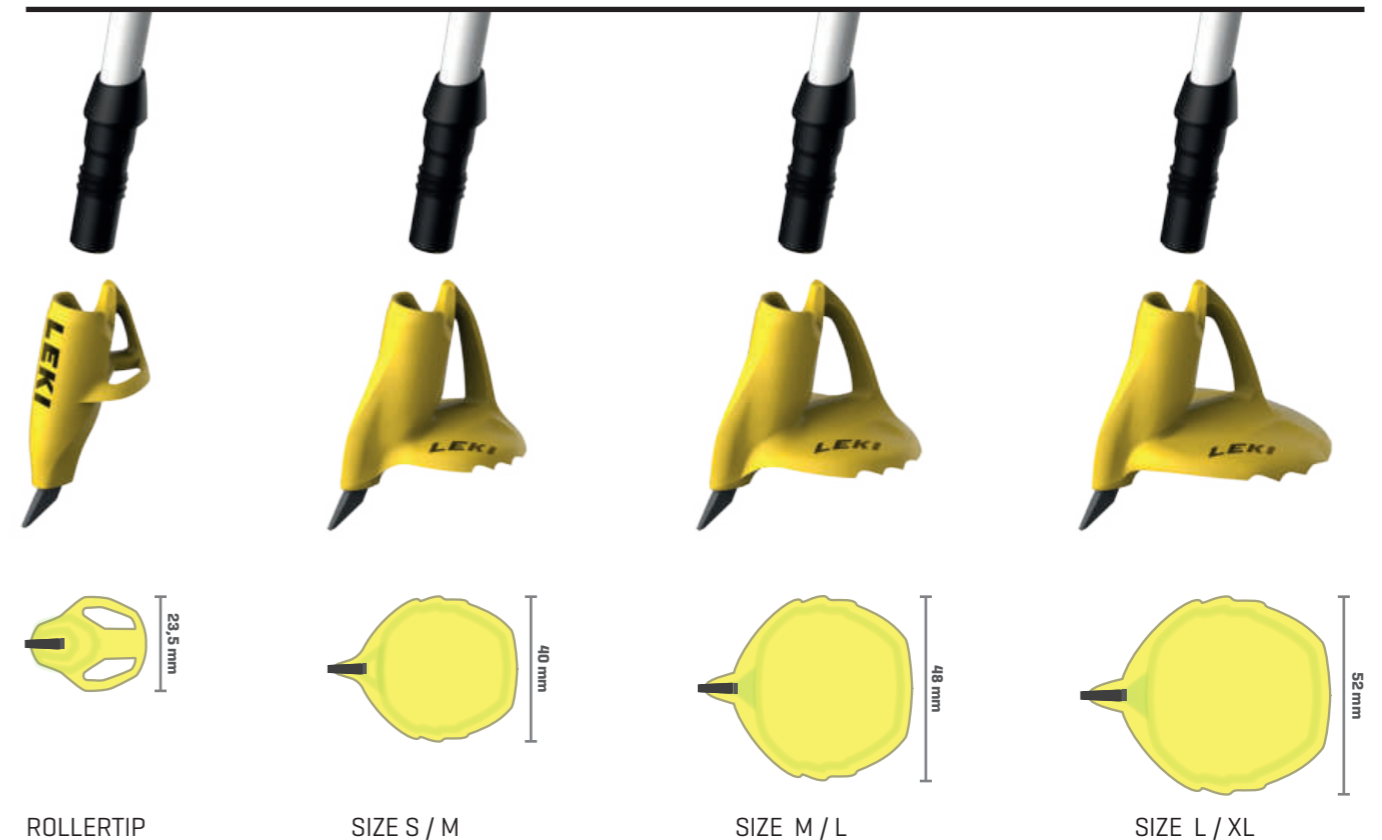

ROLLERTIP

SIZE S / M

SIZE M / L

SIZE L / XL

# TRAIL RUNNING TIP



- Leichte, ausrichtungsfreie Spitze
- Konkave Spitzenform gibt Halt unter jedem Winkel
- Optimiertes Schwungverhalten
- *Light, alignment-free tip*
- *Concave spike form provides foothold in each angle*
- *Optimum swing action*
- *Pointe légère, et non directionnelle*
- *Pointe concave pour assurer le maintien sous n'importe quel angle*
- *Swing et équilibre du bâton optimisés*
- *Puntale leggera con allineamento libero*
- *La forma concava dei puntali assicura la tenuta con qualunque angolazione*
- *Bilanciamento ottimizzato*



# SILENT SPIKE PAD



- Perfekte Ergänzung zu Trail Tip / Speed Tip / Flex Tip
- Sehr guter Halt durch eingearbeitete Hartmetall-Stifte
- Zusätzliche Dämpfungseigenschaften durch das Pad
- Geräuscharmer Stockeinsatz
- Langlebig / abriebfest durch vulkanisierte Gummimischung
- *Perfect accessory for Trail Tip / Speed Tip / Flex Tip*
- *Very good foothold thanks to incorporated hard metal pins*
- *Additional shock absorption due to the rubber pad*
- *Low-noise pole plant*
- *Durable / abrasion-proof due to vulcanized rubber compound*
- *Complément parfait aux pointes Trail Tip / Speed Tip / Flex Tip*
- *Très bon maintien grâce aux matériaux en carbure intégré*
- *Amortissement des vibrations grâce à l'utilisation du caoutchouc*
- *Limitation du bruit généré à chaque pas*
- *Fabrication en caoutchouc vulcanisé durable et résistant à l'abrasion*
- *Il complemento perfetto per Trail Tip / Speed Tip / Flex Tip*
- *Ottima tenuta grazie ai perni integrati in metallo duro*
- *Con questo gommino si ha anche una ammortizzazione*
- *Silenzioso*
- *Buona resistenza all'abrasione grazie alla gomma vulcanizzata*



# SPEED TIP



- Kompromisslos leicht
- Punktgenauer Stockeinsatz
- Optimiertes Schwungverhalten
- *Uncompromisingly light-weight*
- *Precise pole plants*
- *Optimum swing action*
- *Un poids extrêmement faible, sans compromis*
- *Le contrôle du planter du bâton*
- *Swing et équilibre du bâton optimisés*
- *Decisamente più leggera*
- *Puntata più precisa*
- *Bilanciamento ottimizzato*



# SYSTEM TECHNOLOGIES



PERFEKTER SITZ, OPTIMALE FÜHRUNG UND HERRVORRAGENDE KRAFTÜBERTRAGUNG SPEZIELL FÜR DEN NORDISCHEN EINSATZ.

PERFECT FIT, OPTIMUM GUIDANCE AND EXCELLENT POWER TRANSMISSION, ESPECIALLY FOR NORDIC SPORTS. AJUSTEMENT PARFAIT, GUIDAGE OPTIMAL ET EXCELLENT TRANFERT DE PUISSANCE, SPÉCIALEMENT POUR L'UTILISATION EN SKI NORDIQUE. IMPUGNATURA PERFETTA, OTTIMA GUIDA ED ECCELLENTE TRASMISSIONE DELLA FORZA SOPRATTUTTO PER L'USO NELLO SCI NORDICO.



BOA®

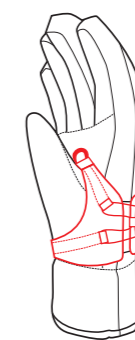

PERFEKTE PASSFORM, DIREKTESTE VERBINDUNG UND DADURCH BESTE KRAFTÜBERTRAGUNG DURCH DIE INTEGRATION VON TRIGGER SHARK UND THE BOA® FIT SYSTEM SPEZIELL FÜR DEN NORDISCHEN EINSATZ.

PERFECT FIT, MOST DIRECT CONNECTION AND THEREFORE BEST POWER TRANSMISSION THROUGH THE INTEGRATION OF TRIGGER SHARK AND THE BOA® FIT SYSTEM ESPECIALLY FOR NORDIC USE. AJUSTEMENT PARFAIT, CONNEXION LA PLUS DIRECTE ET DONC MEILLEUR TRANFERT DE PUISSANCE GRÂCE À L'INTÉGRATION DU TRIGGER SHARK ET DU SYSTÈME BOA® FIT SPÉCIALEMENT CONÇU POUR L'USAGE NORDIQUE. IMPUGNATURA PERFETTA E COLLEGAMENTO DIRETTO E QUINDI MIGLIORE TRASMISSIONE DELLA FORZA ATTRAVERSO L'INTEGRAZIONE DEL SISTEMA TRIGGER SHARK CON IL SISTEMA THE BOA® FIT PER L'USO NELLO SCI NORDICO.

# GLOVE TECHNOLOGIES

## MF TOUCH



EINFACHE BEDIENUNG KAPAZITIVER TOUCHSCREENS OHNE DIE HANDSCHUHE AUSZIEHEN ZU MÜSSEN.

EASY OPERATION OF CAPACITIVE TOUCH SCREENS WITHOUT TAKING OFF THE GLOVES. UTILISATION FACILE DES ÉCRANS TACTILES CAPACITIFS SANS DEVOIR RETIRER LES GANTS. UTILIZZO SEMPLICE DEI TOUCHSCREEN CAPACITIVI, SENZA DOVER TOGLIERE I GUANTI.

# WARMTH LEVEL

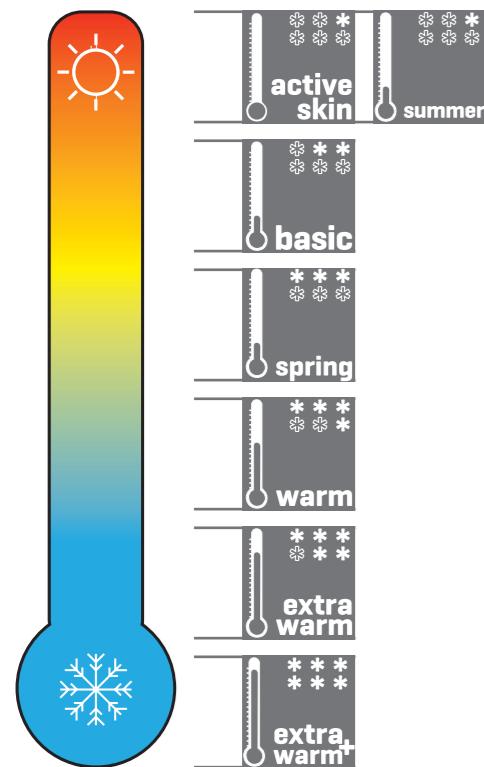

**WÄRMELEVEL BASIEREND AUF**  
 - SHELL-, ISOLATIONS- UND FUTTERMATERIALIEN  
 - HYDROPHOBE EIGENSCHAFTEN  
 - PASSFORM UND KONSTRUKTION

**ZUSÄTZLICHE EINFLUSSFAKTOREN**  
 - INDIVIDUELLES EMPFINDEN  
 - AUSREICHENDE GRÖSSENWAHL DER HANDSCHUHE  
 - GESAMTHEITLICHES BEKLEIDUNGSKONZEPT  
 - PRODUKTPFLEGE UND IMPRÄGNIERUNG

**HEAT LEVEL BASED ON**  
 - SHELL, INSULATION AND LINING MATERIALS  
 - HYDROPHOBIC PROPERTIES  
 - FIT AND CONSTRUCTION  
**ADDITIONAL INFLUENCING FACTORS**  
 - INDIVIDUAL SENSITIVITY  
 - SUFFICIENT GLOVE SIZE SELECTION  
 - OVERALL CLOTHING CONCEPT  
 - PRODUCT CARE AND IMPREGNATION

**NIVEAU DE CHALEUR BASÉ SUR**  
 - MATÉRIAUX EXTÉRIEURS, DE L'ISOLATION ET DE LA DOUBLURE  
 - PROPRIÉTÉS HYDROPHOBES  
 - AJUSTEMENT ET STRUCTURE  
**AUTRES FACTEURS D'INFLUENCE**  
 - RESENTI INDIVIDUEL  
 - TAILLE DE GANTS SUFFISAMMENT GRANDE  
 - CONCEPT VESTIMENTAIRE GLOBAL  
 - ENTRETIEN ET IMPRÉGNATION DU PRODUIT

**LIVELLO DI CALORE CHE SI BASA SU**  
 - MATERIALE SHELL, ISOLANTE E IMBOTTITURA  
 - PROPRIETÀ IDROFOBICHE  
 - VESTIBILITÀ, COSTRUZIONE E STRUTTURA  
**ULTERIORI FATTORI CHE INFLUENZANO**  
 - PERCEZIONE INDIVIDUALE  
 - AMPIA GAMMA DI MISURE  
 - CONCETTO DI ABBIGLIAMENTO A 360°  
 - CURA DEL PRODOTTO E IMPREGNATURA

# HYDROPHOBIC LEVEL

## HYDROPHOBIC FIBERS

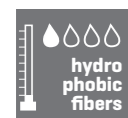

**HYDROPHOBE FASEREIGENSCHAFTEN DER EINGESETZTEN MATERIALIEN.**

**MATERIALS WITH HYDROPHOBIC FIBRE PROPERTIES.**  
 PROPRIÉTÉS HYDROPHOBES DES FIBRES DES MATÉRIAUX UTILISÉS.  
 UTILIZZO DI MATERIALI IDROFOBICI.

# SHELLS

## MICROFIBER, RIBSTOP

**FUNKTIONALE MIKROFASERTEXTILIEN: LEICHT, WASSERABWEISEND UND SCHNELL TROCKNEND.**

**FUNCTIONAL MICROFIBRE TEXTILES: LIGHT, WATER-REPELLENT AND QUICK-DRYING.**

TEXTILES FONCTIONNELS EN MICROFIBRES : LÉGERS, HYDROFUGES ET À SÉCHAGE RAPIDE.

TESSUTI IN MICROFIBRA FUNZIONALI: LEGGERI, IDROREPELLENTI E AD ASCIUGATURA RAPIDA.

# PALM MATERIALS

## AX™ SUEDE / SILICONE AX™ SUEDE

**STRAPAZIERFÄHIG, ANSCHMIEGSAM UND HYDROPHOB. MULTISTRETCH FÜR HÖCHSTEN TRAGEKOMFORT UND PERFEKTEN SITZ. JE NACH MODELL MIT ZUSÄTZLICHEM SILIKONPRINT FÜR NOCH BESSEREN GRIFF.**

**DURABLE, SNUG FIT AND HYDROPHOBIC. MULTISTRETCH FOR HIGHEST WEARING COMFORT AND PERFECT FIT. DEPENDING ON MODEL, WITH ADDITIONAL SILICONE PRINT FOR EVEN BETTER GRIP.**

RÉSISTANT, DOUX ET HYDROPHOBE. MULTISTRETCH POUR UN CONFORT OPTIMAL ET UN AJUSTEMENT PARFAIT. SELON LE MODÈLE AVEC EMPREINTE SILICONÉE SUPPLÉMENTAIRE POUR UNE MEILLEURE PRISE EN MAIN.

RESISTENTE, CONFORTEVOLE E IDROFOBICO. MULTISTRETCH PER UN ELEVATO COMFORT DI INDOSSABILITÀ E MANEGGEVOLEZZA PERFETTA. A SECONDA DEL MODELLO CON ULTERIORE STAMPA IN SILICONE PER UN'ADERENZA ANCORA MAGGIORE.

## NASH / SILICONE NASH

**STRAPAZIERFÄHIG, ANSCHMIEGSAM UND HYDROPHOB. JE NACH MODELL MIT ZUSÄTZLICHEM SILIKONPRINT FÜR NOCH BESSEREN GRIFF.**

**DURABLE, SNUG FIT AND HYDROPHOBIC. DEPENDING ON MODEL WITH ADDITIONAL SILICONE PRINT FOR EVEN BETTER GRIP.**

RÉSISTANT, DOUX ET HYDROPHOBE. SELON LE MODÈLE AVEC EMPREINTE SILICONÉE SUPPLÉMENTAIRE POUR UNE MEILLEURE PRISE EN MAIN.

RESISTENTE, CONFORTEVOLE E IDROFOBICO. A SECONDA DEL MODELLO CON ULTERIORE STAMPA IN SILICONE PER UN'ADERENZA ANCORA MAGGIORE.

# OVERVIEW POLES

REORDER MODELS 2021

## FOLDING POLES VARIO CROSS TRAIL

### MCT 12 VARIO CARBON

650 26801 Reorder Model 2021



### MCT 12 VARIO CARBON WOMEN

650 26851 Reorder Model 2021



### MCT VARIO TA

650 26601 Reorder Model 2021



### MCT VARIO TA WOMEN

650 26651 Reorder Model 2021



## FOLDING POLES CROSS TRAIL

### MCT SUPERLITE CARBON

651 25561



## FOLDING POLES TREKKING

### BLACK SERIES

649 2900



### MICRO VARIO CARBON ANTISHOCK

649 2063



### MICRO VARIO CARBON

651 20621



### MICRO VARIO CARBON

649 2062 Reorder Model 2021



### MICRO VARIO CARBON LADY ANTISHOCK

649 2039



### MICRO VARIO CARBON LADY

649 2067 Reorder Model 2021



### MICRO VARIO CARBON STRONG

649 2980



### MICRO VARIO TA

649 2075 Reorder Model 2021



### MICRO VARIO TA EVO

651 22451



## ULTRALITE TREKKING

### CARBON TA XTG

649 2160



### SHERPA LITE XTG

649 2135



### MAKALU LITE

649 2108 Reorder Model 2021

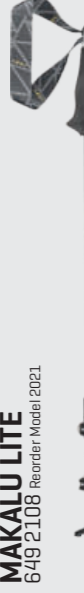

### KHUMBU LITE ANTISHOCK

649 2156



### KHUMBU LITE

649 2153 Reorder Model 2021



### LEGACY LITE ANTISHOCK

651 21831



### LEGACY LITE

651 21841 Reorder Model 2021



### VARIO XS

649 20521



## SUPERSTRONG TREKKING

### SHERPA XTG ANTISHOCK

649 2029



### SHERPA XTG

649 2028



### MAKALU

649 2849 Reorder Model 2021



### KHUMBU ANTISHOCK

649 2026 Reorder Model 2021



### KHUMBU

649 2049 Reorder Model 2021



### LEGACY

651 20191 Reorder Model 2021



## LADIES TREKKING

### MICRO VARIO CARBON LADY ANTISHOCK

649 2059



### MICRO VARIO CARBON LADY

649 2067 Reorder Model 2021



### CRESSIDA ANTISHOCK

649 2115



### CRESSIDA

649 2119 Reorder Model 2021



## SLS VINTAGE LINE TREKKING

### BLACK SERIES SLS XTG

651 21291



### TRAIL ANTISHOCK

650 20351



### TRAIL

650 20211 Reorder Model 2021



### TRAIL LITE

650 21261



### DOLOMIT LITE

650 2834



### VOYAGER

650 20171 Reorder Model 2021



### EAGLE

650 20111



# OVERVIEW POLES

REORDER MODELS 2021

**VARIO** NORDIC WALKING

**TRAVELLER CARBON**  
650 26031

**INSTRUCTOR LITE**  
650 26341

**TRAVELLER ALU**  
650 26011. Reorder Model 2021

**SPIN SHARK SL**  
650 26141

**SPIN**  
650 26161. Reorder Model 2021

**WALKER XS**  
650 26531

**SPEED TIP** NORDIC WALKING

**PACEMAKER LITE**  
650 25501

**PACEMAKER LITE**  
650 25502

**FLASH CARBON**  
650 25601. Reorder Model 2021

**PASSION**  
649 2525

**FLEX TIP** NORDIC WALKING

**RESPONSE**  
650 25201. Reorder Model 2021

**FOLDING FIXED LENGTH** NORDIC WALKING

**MICRO FLASH CARBON**  
651 25821

**LEGEND SERIES** TREKKING

**LEGEND SERIES MICRO**  
650 20871

**LEGEND SERIES**  
650 20861

**WANDERFREUND MAKALU**  
650 20811. Reorder Model 2021

**SUPER MICRO**  
650 20801

**VARIO** SKI ROLLER

**XTA VARIO**  
650 31851

**XTA VARIO JUNIOR**  
650 31841

**FIN VARIO** SKI ROLLER

**PRC MAX**  
643 3131

**PRC 700**  
643 3171

**SMART TIP 2.0** NORDIC WALKING

**SMART PACEMAKER LITE**  
650 25351

**SMART FLASH**  
650 25401

**SMART SUPREME**  
649 2542

**SMART RESPONSE**  
650 25281. Reorder Model 2021

**FOLDING POLES** TRAIL RUNNING

**MICRO TRAIL RACE**  
649 2587. Reorder Model 2021

**MICRO TRAIL PRO**  
649 2585. Reorder Model 2021

**MICRO TRAIL PRO**  
650 25852

**MICRO FLASH CARBON**  
651 25821

**MICRO TRAIL TA**  
650 25751

**MICRO RCM SUPERLIGHT**  
650 25861

**FOLDING POLES VARIO** TRAIL RUNNING

**MICRO TRAIL VARIO**  
649 2674

**MICRO TRAIL VARIO**  
649 2675

**FIXED LENGTH** TRAIL RUNNING

**VERTICAL K**  
649 2592



## IMPRESSUM

SPECIFICATIONS, DESIGNS, TECHNICAL  
INNOVATIONS AND COLOR SUBJECT TO CHANGE WITHOUT  
NOTICE, LEKI SHALL NOT BE LIABLE FOR ERRORS.  
PRINTED IN GERMANY [GO DRUCK MEDIA GMBH & CO. KG]

### COVER

PHILIPP REITER

### PRODUCT PHOTOS

ATELIER BUSCHE

### ACTION & IMAGE PHOTOS

ALEXIS BERG

ATELIER BUSCHE

CHRISTOPH SCHÖCH

CLAUDIA ZIEGLER

JORDI SARAGOSSA

STEPHEN MATERA

TORSTEN WENZLER

PHILIPP REITER

## GERMANY | DEUTSCHLAND

### LEKI Lenhart GmbH

Karl-Arnold-Straße 30 73230 Kirchheim/Teck  
Tel: +49 [0]7021 94 00-0 Fax: +49 [0]7021 94 00-99  
www.leki.com service@leki.de leki.media

## INTERNATIONAL

### ARGENTINA

**SUPERFIT SRL**  
Alicia Moreau de Justo 740  
3 Piso - Oficina 1  
Puerto Madero  
1021 Buenos Aires  
Tel.: +54-11-43340033  
Fax: +54-11-3433157  
luis@superfit1.com

### AUSTRALIA

**VELO-VITA PTY LTD**  
PO Box 882  
Mascot NSW 2020  
Tel: +61 2 9700 7977  
Fax: +61 2 9700 7911  
service@velovita.com.au  
www.velovita.net.au

### AUSTRIA

**LEKI-AUSTRIA HANDELSGES.MBH**  
Wolfurterstr. 4  
6923 Lauterach  
Tel.: +43 [0]5574-62060  
Fax: +43 [0]5574-62060-99  
office@redlersports.at  
www.leki.at

### BENELUX

**LOWA BENELUX B. V.**  
Jupiterstraat 2  
6468 EV Kerkrade  
Tel.: +31 [0]45-5466611  
Fax: +31 [0]45-5466621  
verkoop@leki.nl  
www.leki.nl

### CANADA

**SPORT DINACO INC.**  
4330 Joseph Dubreuil  
Lachine, Québec H8T 3C4  
Tel : +1-514 636-8081  
Toll Free: 1-800-567-9503  
Fax: +1-514 636-0042  
support@sportdinaco.com  
www.sportdinaco.com

### P.R. CHINA

**NANJING B.C. SPORTS PRODUCTS CO. LTD**  
13th or 14th Floor  
03 Building Accelerator  
Newtown Science & Technology Park  
No. 18 East Jialing River Street  
210019 Nanjing, Jiangsu  
Tel.: +86 25 8699 5248  
Fax: +86 25 8690 7480  
bc@bc-sports.com.cn  
www.bc-sports.com.cn

### CZECH REPUBLIC | SLOVAKIA | HUNGARY

**LEVELSPORTKONCEPT S.R.O.**  
K Bílému Vrchu 2978/5  
Horní Počernice  
193 00 Praha 9  
Tel.: +420-284 840 310  
Fax: +420-284 840 314  
info@levelsportkoncept.cz  
www.levelsportkoncept.cz

### DENMARK | GREENLAND | FAROE ISLANDS

**SKITECH APS**  
Golfvej 10  
7400 Herning  
Tel.: +45 97121612  
Fax: +45 97122412  
leb@skitech.dk

### FINLAND

**NOMADE COLLECTION LTD**  
Meijerinkatu / Meijerigatan 7  
65100 Vaasa / Vasa  
Tel.: +358 50 45 47 832  
kimmoo@nonamesport.com

### FRANCE

**O2D S.A.R.L.**  
Rue du Louvasset  
38500 Voiron  
Tel.: +33 [0] 476 670511  
Fax: +33 [0] 476 059601  
service-o2d@wanadoo.fr  
www.leki.com/fr

### GREECE

**DIMITRIADIS S.A**  
10 Molierou st. Metamorfosí  
14452 Athens  
Tel.: +30 211 7056184  
Fax: +30 6936251947  
tryfonk@dimitriadis.gr  
www.dimitriadis.com.gr

### HONG KONG

**MOUNTAIN SERVICES INTERNATIONAL LTD.**  
Shop 1, 52-56 King's Road,  
North Point  
Hong Kong  
Tel.: +852-2541-8876  
Fax: +852-2541-7994  
info@mshk.com.hk

### ICELAND

**ÚTILÍF SKRIFSTOFA**  
Hagasmári 1  
201 Kópavogur  
Tel.: +354 545 1500  
Fax: +354 522 8001  
utilif@utilif.is  
www.utilif.is

### ITALY

**PLANCKER ALEX**  
Plan da Tiejá 38  
39048 Selva Val Gardena - Wolkenstein  
Tel./Fax +39-0471-790031  
info@alexplancker.com  
www.alexplancker.com

### JAPAN

**CARAVAN CO., LTD.**  
25-7, 1-Chome, Sugamo, Toshima-Ku  
Tokyo 170-0002  
Tel.: +81[0]3-3944-2331  
Fax: +81[0]3-3944-6540  
www.caravan-web.com

### KOREA

**MED OUTDOOR CORPORATION**  
1st Floor, 222 Tojeong-ro, Mapo-gu  
Seoul 04091  
Tel.: +82 [0]2-714-8781  
Fax: +82 [0]2-719-8784  
medcompany@empas.com  
www.leki.kr

### LATVIA

**R.A. SERVISS LTD.**  
Outdoor Store VIRSOTNE  
Terbatas Str. 65 - 1001 Riga  
Tel.: +37-1-675 06152  
Fax: +37-1-675 06153  
virsotne@virsotne.lv  
www.virsotne.lv

### LITHUANIA

**SABINA LT, UAB**  
Europos pr. 36  
46369 Kaunas  
Tel.: +370 37 39 11 38  
Fax: +370 37 39 14 24  
info@leki.lt  
www.leki.lt

### NEW ZEALAND

**MOUNTAIN ADVENTURE NZ LTD.**  
2 Dalziel Place, Woolston  
Christchurch 8023  
Tel.: 0800-558 888 / +64-3-375 5000  
info@mountainadventure.co.nz  
www.mountainadventure.co.nz

### NORWAY

**PREMIUM BRANDS AS**  
Sofiemyrveien 10  
1412 Sofiemyr  
Tel. +47 93 40 70 90  
ole@premiumbrands.no  
eba@sportsensation.no

### POLAND

**SPORTIMPEX P.P.H.U.**  
ul. Warszawska 31A  
05-075 Warszawa  
Tel.: +48 22-664 76 32  
Fax: +48 22-664 76 89  
info@sportimpex.pl  
www.leki-nordicwalking.pl

### ROMANIA

**SC ZIPER SPORT SRL**  
Str. Zizinului nr. 121  
500407 Brasov  
Tel: +40 [0]268 331 395  
Fax: +40 [0]268 333 385  
office@zipersport.ro  
www.ski-shop.ro

### RUSSIA | BELARUS

**PERFORMANCE SPORT**  
5/264 Staroalekseevskaya Street  
129626 Moscow  
Tel.: +7-495-637-6261 [1005]  
marketing@psport.ru  
www.trial-sport.ru

### SLOVENIA | CROATIA

**MATIAS 2 D.O.O.**  
Spelina ulica 1  
2000 Maribor  
Tel.: +386-[0]2-426-0126  
Fax: +386-[0]2-461-2741  
info@matias2.si  
www.matias2.si

### SPAIN | PORTUGAL | ANDORRA

**MANUFACTURAS DEPORTIVAS VIPER, S.A.**  
Carrer de la mora 12  
Pol. Ind. Granland - Badalona Sud  
08918 Badalona  
Tel.: +34 93 300 46 00  
Fax: +34 93 300 91 19  
viper@viper-sport.com  
www.viper-sport.com

### SWEDEN

**COMBISPORT AS**  
Östermalmsgatan 132  
591 61 Motala  
Tel.: +46 [0] 141-202700  
Fax: +46 [0] 141-218702  
info@combisport.se  
www.combisport.se

### SWITZERLAND

**LOWA SCHUHE AG**  
Wengelacher 1  
3800 Interlaken  
Tel.: +41 [0]33-8281144  
Fax: +41 [0]33-8281140  
info@lowa.ch  
www.leki.ch

### TAIWAN

**TING SAN IOU MOUNTAIN EQUIPMENT CO., LTD.**  
**OUTDOORPLUS INTERNATIONAL CO.**  
12 F., No.120-1, Qiaohu Rd.,  
Zhonghe Dist.,  
New Taipei City 235, Taiwan [R.O.C.]  
Tel.: +886-2-2243-5662  
Fax: +886-2-2243-4955  
service@tingsaniou.com.tw  
www.tingsaniou.com.tw

### TURKEY

**BAHRIYELI DOGA SPORLARI SN TIC LTD STI**  
Ivedik O.S.B. 1354.cd 1376.sk No. 32  
06030 Ostim / Ankara  
Tel.: +90-312 311 0350  
Fax: +90-312 324 0797  
bahriyeli@bahriyeli.com.tr  
www.bahriyeli.com.tr

### UKRAINE

**RAID-EXTREEM**  
Ukrain  
182-B Borshagovskaya Str.  
03058 Kiev  
marketing@drive-sport.com

### UNITED KINGDOM

**ARDBLAIR SPORTS IMP. LTD.**  
Yard Road  
Blairgowrie/Perthshire  
PH10 6NW  
Tel.: +44 [0]1250-873863  
Fax: +44 [0]1250-875289  
admin@ardblairsports.com  
www.ardblairsports.com

### USA

**LEKI USA, INC.**  
458 Sonwil Drive  
Buffalo, NY 14225  
Tel.: 1-800-255-9982  
Fax: 1-800-291-2161  
service@leki.com  
www.leki.com/us